



Newnan City Council Meeting (New Business)

JANUARY 11, 2022

Newnan City Hall
Richard A. Bolin Council Chambers
25 LaGrange Street
2:30 PM

CALL TO ORDER

INVOCATION

SWEARING IN CEREMONY

- A. Keith Brady - Mayor - At Large
- Rhodes Shell - District 2 - Post A
- Ray DuBose - District 2 - Post B

ELECTION OF MAYOR PRO TEM

APPOINTMENT OF CITY OFFICIALS

- B. Department Heads
- City Attorney
- Municipal Court Judge
- Municipal Court Judge Pro Tem
- Municipal Court Solicitor

REPORTS OF BOARDS AND COMMISSIONS

- C. 1 Appointment- Keep Newnan Beautiful, 3 year term
- D. 1 Appointment- Housing Authority, 5 year term
- E. 2 Appointments- Parks Commission, 3 year terms
- F. 3 Appointments- Planning Commission, 3 year terms
- G. 2 Appointments- Tree Commission, 3 year terms

REPORTS ON OPERATIONS BY CITY MANAGER

- H. Schedule City Floating Holiday for 2022

REPORTS AND COMMUNICATIONS FROM MAYOR

NEW BUSINESS

- I. Ordinance to Provide for the Adoption of a Budget, Its Execution and Effect for the Fiscal Year Beginning January 1, 2022 and Ending December 31, 2022
- J. Adoption of 2022 Pay Plan Update
- K. Public Hearing- Application for Alcohol Beverage License - Grand Cafe, LLC dba Big Joe's Bar & Grille - Retail on Premise (Pouring) Sales of Distilled Spirits, Malt Beverages and Wine - 1329 Bullsboro Dr. - Reason: Personnel

- L. Consideration of Amendment to Chapter 3, Alcoholic Beverages, of the Code of Ordinances of the City of Newnan, to amend residency requirement for licensee
- M. Consideration of Construction Contract Award, Budget and Funding for City Hall Reception Desk
- N. Consideration of Contract Award for Storm Debris Clean-up on City Owned Property
- O. Request to Abandon Public Right of Way
- P. Consideration of an Agreement between the City of Newnan and the Friends of LINC, Inc. to support and promote the LINC multi-use trail in Newnan, Georgia
- Q. Consideration of MEAG sale of Georgia Public Web assets
- R. Appointment of Voting Delegate for Cities United Summit

VISITORS, PETITIONS, COMMUNICATIONS & COMPLAINTS

- S. Request from Bike Coweta to close South Court Sq on April 23, 2022 from 12pm-8pm for Rock & Road Festival

MOTION TO ENTER INTO EXECUTIVE SESSION

- T. Motion to Enter into Executive Session

ADJOURNMENT

BUDGET ORDINANCE

AN ORDINANCE TO PROVIDE FOR THE ADOPTION OF A BUDGET, ITS EXECUTION AND EFFECT FOR THE FISCAL YEAR BEGINNING JANUARY 1, 2022 AND ENDING DECEMBER 31, 2022.

Section I.

There is hereby adopted for the fiscal year January 1, 2022 through December 31, 2022, a budget for the City of Newnan, Georgia, based on the budget prepared by the City Manager, as amended by City Council.

Section II. General Fund (100)

There is hereby established a General Fund for the City of Newnan with an appropriation of \$30,789,700 for the general operation and legal obligation in 2022.

General Fund Revenues	
Property Taxes	\$7,704,500
Sales Taxes	\$9,500,000
Excise (Franchise) Taxes	\$5,485,000
Occp. Tax & Alcohol	
Licenses	\$3,267,000
Inspections & Permits	\$685,500
Fines & Forfeitures	\$745,000
Other Local Revenue	\$437,200
Intergovernmental	\$735,000
Water & Light Transfers	\$1,750,000
Other Financing Sources	\$480,500
	<u>\$30,789,700</u>
General Fund Expenditures	
General Government	\$8,439,445
Public Safety	\$14,569,405
Public Works	\$3,155,886
Community Development	\$3,361,951
Other Services	\$1,263,013
	<u>\$30,789,700</u>

Section III. Street Improvement Fund (200).

There is hereby established a Street Improvement Fund for the City of Newnan with an appropriation of \$429,000 for street improvements.

Street Improvements Revenue	
Street Improvements	\$5,000
LMIG Contract Revenue	\$428,192
Interest Earnings	1,500
Fund Balance Reserves	(\$5,692)
	<u>\$429,000</u>
Street Improvements Expenditures	
Major Streets Maintenance	\$429,000
	<u>\$429,000</u>

Section IV. Confiscated Assets Fund (210)

There is hereby established a Confiscated Assets Fund for the City of Newnan with an appropriation of \$138,000 for Public Safety operations. This fund consists of confiscated and condemned funds released by the Superior Court for Police Department purchases.

Confiscated Assets Revenue	
DOT Condemnations	\$68,000
DOJ Condemnations	\$5,000
Other Police Seizures	\$12,500
Interest Earnings	\$47
Fund Balance Reserves	\$52,453
	<u>\$138,000</u>
Confiscated Assets Expenditures	
Other Seizures Expenditures	\$81,000
Dept. of Justice Expenditures	\$5,000
Dept. of Treasury Expenditures	\$52,000
	<u>\$138,000</u>

Section V. NSP1 Grant Fund (221)

There is hereby established a NSP1 Grant Fund for the City of Newnan with an appropriation of \$125,000. This fund is utilized to account for a Neighborhood Stabilization Program grant received by the City from the Georgia Department of Community Affairs to purchase and rehabilitate housing for low income recipients who meet the eligibility guidelines for assistance. Newnan Housing Authority (HAN) and Newnan-Coweta Habitat for Humanity (NCHFH) are the sub-recipients of the grant.

NSP1 Revenues	
Program Income	\$185,000
Interest Earnings	\$100
Fund Balance Reserves	(\$60,100)
	<u>\$125,000</u>
NSP1 Expenditures	
Program Expenses	\$125,000
	<u>\$125,000</u>

Section VI. NSP3 Grant Fund (222)

There is hereby established a NSP3 Grant Fund for the City of Newnan with an appropriation of \$125,000. This fund is utilized to account for a Neighborhood Stabilization Program grant received by the City from the Georgia Department of Community Affairs to purchase and rehabilitate housing for low income recipients who meet the eligibility guidelines for assistance. Newnan Housing Authority (HAN) is the sub-recipient of the grant.

NSP3 Revenue	
Program Income	\$125,000
Interest Income	\$100
Fund Balance Reserves	(\$100)
	<u>\$125,000</u>
NSP3 Expenditures	
Program Expenses	\$125,000
	<u>\$125,000</u>

Section VII. Miscellaneous Grants Fund (240)

There is hereby established a Miscellaneous Grants Fund for the City of Newnan with an appropriation of \$44,050. This fund is utilized for grants received by the city from local vendors, DCA and other agencies to fund specific expenditures as required.

Misc. Grants Revenue	
Grant Funds & Donations	\$45,000
Fund Balance Reserves	<u>(\$950)</u>
	<u>\$44,050</u>
Misc. Grants Expenditures	
Employee Benefits	\$2,000
Employee Recognition	\$1,200
Public Relations	\$5,000
Materials & Supplies	\$7,965
Training	\$1,835
Protective Equipment	\$23,500
Minor Equipment	\$2,500
Landscaping Supplies	<u>\$1,000</u>
	<u>\$44,050</u>

Section VII. Hotel/Motel Tourism Fund (275)

There is hereby established a Hotel/Motel Tourism Fund for the City of Newnan with an appropriation of \$1,053,000 for Tourism Enhancement activities.

Hotel/Motel Tourism Revenues	
Hotel/Motel Tax	\$1,053,000
Interest Earnings	\$1,000
Fund Balance Reserves	<u>(\$1,000)</u>
	<u>\$1,053,000</u>
Hotel/Motel Tourism Expenditures	
Transfer to Explore Newnan - Coweta	\$405,000
Transfer to General Fund	\$405,000
Transfer to Newnan Centre	<u>\$243,000</u>
	<u>\$1,053,000</u>

Section IX. Motor Vehicle Rental Excise Tax Fund (280)

There is hereby established a Motor Vehicle Rental Excise Tax Fund for the City of Newnan with an appropriation of \$98,000 for Newnan Centre activities.

Motor Vehicle Rental Excise Tax Revenues	
Excise Tax	\$95,000
Interest Earnings	\$500
Fund Balance Reserves	\$2,500
	<u>\$98,000</u>
Motor Vehicle Rental Excise Tax Expenditures	
Natural Gas	\$3,000
Transfer to Newnan Centre	\$95,000
	<u>\$98,000</u>

Section X. Special Purpose Local Option Sales Tax Funds (323 and 310)

Fund 323, **SPLOST 2013**, was established in 2013 and expired in 2018. This year's budget includes an appropriation of \$800,000 for capital projects.

SPLOST 2013 Revenues	
Interest Earnings	\$500
Fund Balance Reserves	\$799,500
	<u>\$800,000</u>
SPLOST 2013 Expenditures	
Intelligent Traffic Operations	\$200,000
Recreation Improvements	\$600,000
	<u>\$800,000</u>

Fund 310, **SPLOST 2019**, was established in 2019 and will expire in 2024. This year’s budget includes an appropriation of \$8,480,000 for capital projects and a transfer to Newnan Utilities in the amount of \$720,000 for a total of \$9,200,000.

SPLOST 2019 Revenue:

SPLOST 2019 Receipts	\$7,200,000
Interest Earnings	\$7,000
Fund Balance Reserves	\$1,993,000
	<u>\$9,200,000</u>

SPLOST 2019 Expenditures:

Public Safety	\$1,500,000
Streets, Drainage & Sidewalks	\$1,000,000
Street, Intersection & Parking Improvements	\$3,600,000
Lower Fayetteville Road	\$400,000
Public Works Equipment	\$180,000
Path & Linear Parks	\$1,800,000
Transfer to Newnan Utilities	\$720,000
	<u>\$9,200,000</u>

Section XI. Impact Fees (375)

There is hereby established an Impact Fees Fund for the City of Newnan with an appropriation of \$625,000. In 2004, the City established an impact fee program with funds to be paid into the fund for four major areas of development: Roads and Bridges, Fire, Police and Parks.

Impact Fees Revenues	
Roads/Streets/Bridges	\$250,000
Fire Services	\$295,000
Parks/Recreation	\$400,000
Interest Earnings	\$220
Fund Balance Reserves	(\$320,220)
	<u>\$625,000</u>
Impact Fees Expenditures	
Parks/Recreation	\$625,000
	<u>\$625,000</u>

Section XII. Sanitation Fund (540)

There is hereby established a Sanitation Fund for the City of Newnan with an appropriation of \$1,028,278. These funds will be used for Brush & Bulk and Refuse (downtown commercial district).

Sanitation Revenues	
Yard Debris & Bulk	
Collections	\$700,000
Garbage Fees - Commercial	\$60,000
Interest Earnings	\$1,500
Transfer from General Fund	\$190,000
Fund Balance Reserves	\$76,778
	<u>\$1,013,341</u>

Sanitation Expenditures	
Brush & Bulk	
Wages & Benefits	\$386,143
Operations	\$355,614
Depreciation Expenses	\$85,000
	<u>\$826,757</u>

Sanitation Expenditures	
Refuse	
Wages & Benefits	\$146,506
Operations	\$55,015
	<u>\$201,521</u>

Section XIII. All revenue received by the City of Newnan from Sources not restricted by law to expenditure for specific purposes may be used in meeting disbursements in Section II. Should the revenue received from such sources exceed the amount estimated, such excess shall be allocated to the General Fund subject to further action by City Council. The total disbursements in any fund shall not exceed the amount appropriated for that fund, including any available fund balances.

Done ratified, and passed by the City Council of the City of Newnan, Georgia, in regular session assembled this eleventh day of January 2022.

ATTEST:

Megan Shea, City Clerk

L. Keith Brady, Mayor

REVIEWED AS TO FORM:

Rhodes H. Shell, Mayor Pro Tem

C. Bradford Sears, Jr., City Attorney

George M. Alexander, Councilmember

Cleatus Phillips, City Manager

Cynthia E. Jenkins, Councilmember

Raymond F. DuBose, Councilmember

Dustin K. Koritko, Councilmember

Paul L. Guillaume, Councilmember

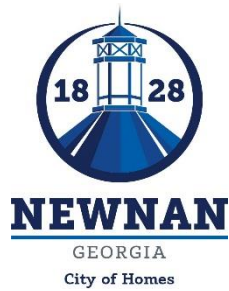

City of Newnan, Georgia - Mayor and Council

Date: January 11, 2022

Agenda Item: Adoption of 2022 Pay Plan Update

Prepared by: Nanette Freeman, Human Resources Director

Purpose: Request to increase overall 2022 Pay Plan minimum and maximum pay ranges by 2.5% for all pay grades: General – Police – Fire.

Background: Last overall Pay Plan increase 01/16/2020. Amended 2021 Pay Plan 07/20/2021 to add 2 positions: Municipal Court Clerk Manager and AARP Special Projects Manager.

Recommendation: Approve the 2022 Pay Plan as presented.

Attachments: Proposed 2022 Pay Plan

Previous Discussions with Council: N/A

**CITY OF NEWNAN, GEORGIA
GENERAL EMPLOYEES
2022 SALARY RANGES BASED ON GRADE
Effective January 20, 2022**

Grade	Classification Title	Exempt (E)		Minimum	Maximum
		Non-exempt (N)			
1				\$ 19,510.40	\$ 30,264.00
				\$ 9.38	\$ 14.55
2				\$ 20,675.20	\$ 32,073.60
				\$ 9.94	\$ 15.42
3				\$ 21,944.00	\$ 33,987.20
				\$ 10.55	\$ 16.34
4				\$ 23,254.40	\$ 36,046.40
				\$ 11.18	\$ 17.33
5				\$ 24,648.00	\$ 38,209.60
				\$ 11.85	\$ 18.37
6				\$ 26,124.80	\$ 40,497.60
				\$ 12.56	\$ 19.47
7				\$ 27,684.80	\$ 42,931.20
				\$ 13.31	\$ 20.64
8				\$ 29,348.80	\$ 45,510.40
				\$ 14.11	\$ 21.88
9	Administrative Assistant - Fire	N		\$ 31,886.40	\$ 49,462.40
	Administrative Assistant - Planning & Zoning	N		\$ 15.33	\$ 23.78
	Administrative Assistant - Police	N			
	Administrative Assistant - Public Works	N			
	Assistant Permit Technician (PT)	N			
	Beautification Worker	N			
	Cemetery Maintenance Worker (FT and Seas)	N			
	Clerk-Municipal Court	N			
	Clerk-Police (FT and PT)	N			
	Crossing Guard (PT)	N			
	Facilities Attendant (PT and FT)	N			
	Receptionist	N			
	Reference Assistant (PT)	N			
	Sanitation Collection Worker	N			
	Senior Carnegie Assistant (PT)	N			
	Street Maintenance Worker	N			
	Trolley Driver (PT)	N			

**CITY OF NEWNAN, GEORGIA
GENERAL EMPLOYEES
2022 SALARY RANGES BASED ON GRADE
Effective January 20, 2022**

Grade	Classification Title	Exempt (E)		Minimum	Maximum
		Non-exempt (N)			
10	Accounting Technician (FT and PT)	N		\$ 33,800.00	\$ 52,395.20
	Beautification Crew Leader	N		\$ 16.25	\$ 25.19
	Cemetery Equipment Operator	N			
	Inmate Crew Supervisor	N			
	Permit Technician	N			
	Sanitation Equipment Operator	N			
	Senior Beautification Worker	N			
	Senior Facilities Attendant	N			
	Senior Street Maintenance Worker	N			
	Street Maintenance/Concrete Finisher	N			
11	Animal Control Officer	N		\$ 35,817.60	\$ 55,536.00
	Communications Operator	N		\$ 17.22	\$ 26.70
	Fleet Coordinator	N			
	Parking Enforcement Officer	N			
	Special Events Coordinator	N			
12	Automotive Mechanic	N		\$ 38,001.60	\$ 58,884.80
	Erosion Control Inspector	N		\$ 18.27	\$ 28.31
	Facilities Maintenance Technician	N			
	KNB Coordinator	N			
	Sanitation Driver/Collector	N			
	Senior Accounting Technician	N			
13	Deputy Court Clerk	N		\$ 40,268.80	\$ 62,420.80
	Leisure Services Coordinator	N		\$ 19.36	\$ 30.01
14	Accounting Specialist	N		\$ 42,681.60	\$ 66,164.80
	Beautification Supervisor	N		\$ 20.52	\$ 31.81
	Building Inspector	N			
	Code Enforcement Officer	N			
	Communications Specialist	N			
	Human Resources Coordinator	N			

**CITY OF NEWNAN, GEORGIA
GENERAL EMPLOYEES
2022 SALARY RANGES BASED ON GRADE
Effective January 20, 2022**

Grade	Classification Title	Exempt (E)		Minimum	Maximum
		Non-exempt (N)			
15	Cemetery Maint Supervisor	N		\$ 45,240.00	\$ 70,116.80
	Information Tech Systems Analyst	N		\$ 21.75	\$ 33.71
	Lead Mechanic	N			
	Municipal Court Clerk	N			
	Street Maintenance Supervisor	N			
16	Accountant	N		\$ 47,964.80	\$ 74,360.00
	Beautification Manager	N		\$ 23.06	\$ 35.75
	Engineering Field Inspector	N			
	Senior Building Inspector	N			
	Senior Facilities Maintenance Supervisor	N			
17	Human Resources Specialist	N		\$ 50,856.00	\$ 78,790.40
	IT Senior Systems Analyst	N		\$ 24.45	\$ 37.88
	Main Street Manager	N			
	Plans Examiner	N			
18	Cemetery Superintendent	E		\$ 53,892.80	\$ 83,532.80
	City Clerk	E		\$ 25.91	\$ 40.16
	Communications Manager	E			
	Planner	N			
	Sanitation Superintendent	N			
	Street Superintendent	N			
19	GIS Analyst II	N		\$ 57,116.80	\$ 88,545.60
	Municipal Court Clerk Manager	E		\$ 27.46	\$ 42.57
20	Carnegie Director	E		\$ 60,548.80	\$ 93,849.60
	Deputy Building Official	N		\$ 29.11	\$ 45.12
	Deputy Public Works Director	E			
	Facilities Maintenance Director	E			
	Leisure Services Manager	E			
	ARPA Special Projects Manager	E			

**CITY OF NEWNAN, GEORGIA
GENERAL EMPLOYEES
2022 SALARY RANGES BASED ON GRADE
Effective January 20, 2022**

Grade	Classification Title	Exempt (E)		Minimum	Maximum
		Non-exempt (N)			
21	Assistant Finance Director	E		\$ 64,168.00	\$ 99,486.40
	Civil Engineer	E		\$ 30.85	\$ 47.83
	Program Manager	E			
22	Business Development Director	E		\$ 68,057.60	\$ 105,476.80
	Landscape Architect	E		\$ 32.72	\$ 50.71
23	Chief Building Official	E		\$ 72,113.60	\$ 111,779.20
	Human Resources Director	E		\$ 34.67	\$ 53.74
	Information Technology Director	E			
	Planning and Zoning Director	E			
24				\$ 76,460.80	\$ 118,497.60
				\$ 36.76	\$ 56.97
25	Finance Director	E		\$ 81,036.80	\$ 125,611.20
	Public Works Director	E		\$ 38.96	\$ 60.39
	City Engineer	E			
26				\$ 85,904.00	\$ 133,120.00
				\$ 41.30	\$ 64.00
27	Assistant City Manager	E		\$ 91,062.40	\$ 141,148.80
				\$ 43.78	\$ 67.86
28				\$ 96,532.80	\$ 149,593.60
				\$ 46.41	\$ 71.92
29				\$ 102,294.40	\$ 158,558.40
				\$ 49.18	\$ 76.23
30				\$ 108,451.20	\$ 168,084.80
				\$ 52.14	\$ 80.81

*Annual Salary Based on 2,080 Hours Per Year

Salary Range - GENERAL

	Minimum		Mid		Maximum
1	\$ 9.38		\$ 11.97		\$ 14.55
2	\$ 9.94		\$ 12.68		\$ 15.42
3	\$ 10.55		\$ 13.45		\$ 16.34
4	\$ 11.18		\$ 14.26		\$ 17.33
5	\$ 11.85		\$ 15.11		\$ 18.37
6	\$ 12.56		\$ 16.02		\$ 19.47
7	\$ 13.31		\$ 16.98		\$ 20.64
8	\$ 14.11		\$ 18.00		\$ 21.88
9	\$ 15.33		\$ 19.56		\$ 23.78
10	\$ 16.25		\$ 20.73		\$ 25.19
11	\$ 17.22		\$ 21.97		\$ 26.70
12	\$ 18.27		\$ 23.29		\$ 28.31
13	\$ 19.36		\$ 24.68		\$ 30.01
14	\$ 20.52		\$ 26.17		\$ 31.81
15	\$ 21.75		\$ 27.74		\$ 33.71
16	\$ 23.06		\$ 29.41		\$ 35.75
17	\$ 24.45		\$ 31.17		\$ 37.88
18	\$ 25.91		\$ 33.04		\$ 40.16
19	\$ 27.46		\$ 35.01		\$ 42.57
20	\$ 29.11		\$ 37.12		\$ 45.12
21	\$ 30.85		\$ 39.34		\$ 47.83
22	\$ 32.72		\$ 41.71		\$ 50.71
23	\$ 34.67		\$ 44.21		\$ 53.74
24	\$ 36.76		\$ 46.86		\$ 56.97
25	\$ 38.96		\$ 49.67		\$ 60.39
26	\$ 41.30		\$ 52.65		\$ 64.00
27	\$ 43.78		\$ 55.81		\$ 67.86
28	\$ 46.41		\$ 59.16		\$ 71.92
29	\$ 49.18		\$ 62.71		\$ 76.23
30	\$ 52.14		\$ 66.47		\$ 80.81

CITY OF NEWNAN, GEORGIA
POLICE CERTIFIED
2022 SALARY RANGES BASED ON GRADE
Effective January 20, 2022

Grade	Classification Title	Exempt (E) Non-exempt (N)	Minimum	Maximum
1			\$ 24,648.00 \$ 11.85	\$ 38,209.60 \$ 18.37
2	Police Recruit	N	\$ 25,480.00 \$ 12.25	\$ 40,476.80 \$ 19.46
3			\$ 27,684.80 \$ 13.31	\$ 42,910.40 \$ 20.63
4			\$ 29,348.80 \$ 14.11	\$ 45,489.60 \$ 21.87
5			\$ 31,137.60 \$ 14.97	\$ 48,256.00 \$ 23.20
6			\$ 33,009.60 \$ 15.87	\$ 51,168.00 \$ 24.60
7			\$ 34,985.60 \$ 16.82	\$ 54,225.60 \$ 26.07
8			\$ 37,065.60 \$ 17.82	\$ 57,449.60 \$ 27.62
9			\$ 39,291.20 \$ 18.89	\$ 60,902.40 \$ 29.28
10	Police Officer - Community Resources	N	\$ 41,662.40	\$ 64,584.00
	Police Officer - Crime Scene Tech	N	\$ 20.03	\$ 31.05
	Police Officer - Master Officer	N		
	Police Officer - Patrol	N		
	Police Officer - School Resources	N		
	Police Officer - Traffic	N		
11			\$ 44,158.40 \$ 21.23	\$ 68,452.80 \$ 32.91

CITY OF NEWNAN, GEORGIA
POLICE CERTIFIED
2022 SALARY RANGES BASED ON GRADE
Effective January 20, 2022

Grade	Classification Title	Exempt (E)		Minimum	Maximum
		Non-exempt (N)			
12	Crime Scene Tech	N		\$ 46,800.00	\$ 72,550.40
	Police Accred Coordinator	N		\$ 22.50	\$ 34.88
	Police Corporal - Patrol	N			
	Police Corporal - Community Resource	N			
	Police Corporal - School Resources	N			
	Police Investigator	N			
13	Detective	N		\$ 49,608.00	\$ 76,897.60
				\$ 23.85	\$ 36.97
14	Detective Sergeant	N		\$ 52,603.20	\$ 81,536.00
	Sergeant Community Resources	N		\$ 25.29	\$ 39.20
	Sergeant - Patrol	N			
	Sergeant - School Resources	N			
	Sergeant - Traffic	N			
	Sergeant - Training	N			
15				\$ 55,744.00	\$ 86,403.20
				\$ 26.80	\$ 41.54
16	Police Lieutenant - Detectives	N		\$ 59,092.80	\$ 91,603.20
	Police Lieutenant - Patrol	N		\$ 28.41	\$ 44.04
	Police Lieutenant - Prof Standards	N			
	Police Lieutenant - Training	N			
	Police Lieutenant - Traffic	N			
17				\$ 62,628.80	\$ 97,073.60
				\$ 30.11	\$ 46.67
18	Captain - Uniform	E		\$ 66,393.60	\$ 102,918.40
	Captain - Community	E		\$ 31.92	\$ 49.48
19				\$ 70,387.20	\$ 109,096.00
				\$ 33.84	\$ 52.45

CITY OF NEWNAN, GEORGIA
POLICE CERTIFIED
2022 SALARY RANGES BASED ON GRADE
Effective January 20, 2022

Grade	Classification Title	Exempt (E) Non-exempt (N)	Minimum	Maximum
20			\$ 74,588.80 \$ 35.86	\$ 115,606.40 \$ 55.58
21	Deputy Chief of Police	E	\$ 79,081.60 \$ 38.02	\$ 122,574.40 \$ 58.93
22			\$ 83,824.00 \$ 40.30	\$ 129,937.60 \$ 62.47
23			\$ 88,857.60 \$ 42.72	\$ 137,737.60 \$ 66.22
24	Chief of Police	E	\$ 94,182.40 \$ 45.28	\$ 145,974.40 \$ 70.18
25			\$ 99,840.00 \$ 48.00	\$ 154,752.00 \$ 74.40
26			\$ 105,830.40 \$ 50.88	\$ 164,028.80 \$ 78.86
27			\$ 112,195.20 \$ 53.94	\$ 173,908.80 \$ 83.61
28			\$ 118,913.60 \$ 57.17	\$ 184,308.80 \$ 88.61
29			\$ 126,068.80 \$ 60.61	\$ 195,416.00 \$ 93.95
30			\$ 133,640.00 \$ 64.25	\$ 207,147.20 \$ 99.59

*Annual Salary Based on 2,080 Hours Per Year

**CITY OF NEWNAN, GEORGIA
POLICE SWORN OFFICERS
2022 SALARY RANGES BASED ON GRADE
Effective January 20, 2022**

POLICE

	Minimum		Mid		Maximum
1	\$ 11.85		\$ 15.11		\$ 18.37
2	\$ 12.56		\$ 16.01		\$ 19.46
3	\$ 13.31		\$ 16.97		\$ 20.63
4	\$ 14.11		\$ 17.99		\$ 21.87
5	\$ 14.97		\$ 19.09		\$ 23.20
6	\$ 15.87		\$ 20.24		\$ 24.60
7	\$ 16.82		\$ 21.45		\$ 26.07
8	\$ 17.82		\$ 22.72		\$ 27.62
9	\$ 18.89		\$ 24.09		\$ 29.28
10	\$ 20.03		\$ 25.54		\$ 31.05
11	\$ 21.23		\$ 27.07		\$ 32.91
12	\$ 22.50		\$ 28.69		\$ 34.88
13	\$ 23.85		\$ 30.41		\$ 36.97
14	\$ 25.29		\$ 32.25		\$ 39.20
15	\$ 26.80		\$ 34.17		\$ 41.54
16	\$ 28.41		\$ 36.23		\$ 44.04
17	\$ 30.11		\$ 38.39		\$ 46.67
18	\$ 31.92		\$ 40.70		\$ 49.48
19	\$ 33.84		\$ 43.15		\$ 52.45
20	\$ 35.86		\$ 45.72		\$ 55.58
21	\$ 38.02		\$ 48.48		\$ 58.93
22	\$ 40.30		\$ 51.39		\$ 62.47
23	\$ 42.72		\$ 54.47		\$ 66.22
24	\$ 45.28		\$ 57.73		\$ 70.18
25	\$ 48.00		\$ 61.20		\$ 74.40
26	\$ 50.88		\$ 64.87		\$ 78.86
27	\$ 53.94		\$ 68.78		\$ 83.61
28	\$ 57.17		\$ 72.89		\$ 88.61
29	\$ 60.61		\$ 77.28		\$ 93.95
30	\$ 64.25		\$ 81.92		\$ 99.59

CITY OF NEWNAN, GEORGIA
FIRE CERTIFIED
2022 SALARY RANGES BASED ON GRADE
Effective January 20, 2022

Grade	Classification Title	Exempt (E) Non-exempt (N)	Minimum	Maximum
1			\$ 24,625.92 \$ 8.48	\$ 38,158.56 \$ 13.14
2	Fire Recruit (2080 hours)		\$ 18,699.20 \$ 8.99	\$ 28,974.40 \$ 13.93
3			\$ 27,675.12 \$ 9.53	\$ 42,892.08 \$ 14.77
4			\$ 29,359.44 \$ 10.11	\$ 45,505.68 \$ 15.67
5			\$ 31,101.84 \$ 10.71	\$ 48,206.40 \$ 16.60
6			\$ 32,989.44 \$ 11.36	\$ 51,139.44 \$ 17.61
7			\$ 34,964.16 \$ 12.04	\$ 54,188.64 \$ 18.66
8			\$ 37,084.08 \$ 12.77	\$ 57,470.16 \$ 19.79
9			\$ 39,320.16 \$ 13.54	\$ 60,954.96 \$ 20.99
10	Firefighter/EMT (2904 hours)		\$ 41,672.40 \$ 14.35	\$ 64,584.96 \$ 22.24
11			\$ 44,169.84 \$ 15.21	\$ 68,476.32 \$ 23.58
12			\$ 46,812.48 \$ 16.12	\$ 72,570.96 \$ 24.99
13			\$ 49,629.36 \$ 17.09	\$ 76,926.96 \$ 26.49
14	Fire Lieutenant (2904 hours)	N	\$ 52,591.44 \$ 18.11	\$ 81,515.28 \$ 28.07

CITY OF NEWNAN, GEORGIA
FIRE CERTIFIED
2022 SALARY RANGES BASED ON GRADE
Effective January 20, 2022

Grade	Classification Title	Exempt (E) Non-exempt (N)	Minimum	Maximum
15		N	\$ 55,756.80	\$ 86,423.04
		N	\$ 19.20	\$ 29.76
16	Fire Captain (2904 hours)	N	\$ 59,096.40	\$ 91,592.16
	Fire Marshall (2080 hours)	N	\$ 20.35	\$ 31.54
	Training Captain (2080 hours)	N		
17			\$ 62,639.28	\$ 97,080.72
			\$ 21.57	\$ 33.43
18			\$ 66,385.44	\$ 102,888.72
			\$ 22.86	\$ 35.43
19			\$ 70,363.92	\$ 109,074.24
			\$ 24.23	\$ 37.56
20			\$ 74,603.76	\$ 115,637.28
			\$ 25.69	\$ 39.82
21	Battalion Chief (2904 hours)	N	\$ 79,046.88	\$ 122,519.76
			\$ 27.22	\$ 42.19
22			\$ 83,780.40	\$ 129,866.88
			\$ 28.85	\$ 44.72
23			\$ 88,833.36	\$ 137,678.64
			\$ 30.59	\$ 47.41
24	Fire Chief (2080 hours)	E	\$ 94,147.68	\$ 145,926.00
			\$ 32.42	\$ 50.25
25			\$ 99,810.48	\$ 154,696.08
			\$ 34.37	\$ 53.27
26			\$ 105,792.72	\$ 163,988.88
			\$ 36.43	\$ 56.47
27			\$ 112,123.44	\$ 173,804.40
			\$ 38.61	\$ 59.85

**CITY OF NEWNAN, GEORGIA
 FIRE CERTIFIED
 2022 SALARY RANGES BASED ON GRADE
 Effective January 20, 2022**

Grade	Classification Title	Exempt (E) Non-exempt (N)	Minimum	Maximum
28			\$ 118,860.72 \$ 40.93	\$ 184,229.76 \$ 63.44
29			\$ 126,004.56 \$ 43.39	\$ 195,294.00 \$ 67.25
30			\$ 133,554.96 \$ 45.99	\$ 206,997.12 \$ 71.28

CITY OF NEWNAN, GEORGIA
FIRE PERSONNEL
2022 SALARY RANGES BASED ON GRADE
Effective January 20, 2022

FIRE

	Minimum		Mid		Maximum
1	\$ 8.48		\$ 10.81		\$ 13.14
2	\$ 8.99		\$ 11.46		\$ 13.93
3	\$ 9.53		\$ 12.15		\$ 14.77
4	\$ 10.11		\$ 12.89		\$ 15.67
5	\$ 10.71		\$ 13.66		\$ 16.60
6	\$ 11.36		\$ 14.49		\$ 17.61
7	\$ 12.04		\$ 15.35		\$ 18.66
8	\$ 12.77		\$ 16.28		\$ 19.79
9	\$ 13.54		\$ 17.27		\$ 20.99
10	\$ 14.35		\$ 18.30		\$ 22.24
11	\$ 15.21		\$ 19.40		\$ 23.58
12	\$ 16.12		\$ 20.56		\$ 24.99
13	\$ 17.09		\$ 21.79		\$ 26.49
14	\$ 18.11		\$ 23.09		\$ 28.07
15	\$ 19.20		\$ 24.48		\$ 29.76
16	\$ 20.35		\$ 25.95		\$ 31.54
17	\$ 21.57		\$ 27.50		\$ 33.43
18	\$ 22.86		\$ 29.15		\$ 35.43
19	\$ 24.23		\$ 30.90		\$ 37.56
20	\$ 25.69		\$ 32.76		\$ 39.82
21	\$ 27.22		\$ 34.71		\$ 42.19
22	\$ 28.85		\$ 36.79		\$ 44.72
23	\$ 30.59		\$ 39.00		\$ 47.41
24	\$ 32.42		\$ 41.34		\$ 50.25
25	\$ 34.37		\$ 43.82		\$ 53.27
26	\$ 36.43		\$ 46.45		\$ 56.47
27	\$ 38.61		\$ 49.23		\$ 59.85
28	\$ 40.93		\$ 52.19		\$ 63.44
29	\$ 43.39		\$ 55.32		\$ 67.25
30	\$ 45.99		\$ 58.64		\$ 71.28

RESOLUTION TO AMEND 2021 PAY PLAN

WHEREAS, the City of Newnan has a formal pay plan to provide an equitable basis for assigning pay rates for all employees; and

WHEREAS, the pay plan is annually reviewed and updated to reflect changes in classifications and pay grade assignments; and

WHEREAS, the pay plan has been drafted to adjust all pay grades by 2.5%; and

WHEREAS, the pay plan has been drafted to adjust the minimum pay grade assignment at pay grade 9; and

WHEREAS, funds have been provided in the 2022 Budget for the Pay Plan as presented;

NOW, THEREFORE, BE IT RESOLVED, that the 2022 *Pay Plan* which is attached hereto is adopted by the City Council this 11th day of January 2022 and is effective January 20, 2022.

DONE, RATIFIED AND PASSED by the City Council of the City of Newnan, Georgia, this 11th day of January 2022 in regular session assembled.

Attest:

Megan Shea, City Clerk

Keith Brady, Mayor

Rhodes H. Shell, Mayor Pro Tem

Witness:

George M. Alexander, Councilmember

C. Bradford Sears, Jr., City Attorney

Cynthia E. Jenkins, Councilmember

Cleatus W. Phillips, City Manager

Ray DuBose, Councilmember

Dustin Koritko, Councilmember

Paul Guillaume, Councilmember

APPLICATION FOR TRANSFER OF ALCOHOL BEVERAGE LICENSE

Name: **Grand Café, LLC dba Big Joe's Bar & Grille**

Licensee: **Jessica Hojaij**

License Representative: **From: Krystal Erickson
To: Kandria Wynn**

Type License: **Retail On Premise (Pouring) Sales of Distilled Spirits, Malt Beverages & Wine**

Location: **1329 Bullsboro Dr.**

TO THE CITY COUNCIL: REASON – PERSONNEL

(1) The above application with supporting documents and application fee has been filed in the City Clerk's office; reviewed by the appropriate departments of the City and appears to be (complete). (Sec 3-33)

If incomplete, reasons _____

(2) The citizenship requirements (have) been met. (Sec. 3-34)

If not, reasons _____

(3) Residency requirements (have) been met. (Sec. 3-35)

If not, reasons _____

(4) The location appears (to comply) with zoning requirements. (Sec 3-37)

If not, reasons _____

(5) The location of the proposed premises appears (to comply) with the distance requirements set forth in Sec. 3-39.

If not, reasons _____

(6) All taxes or other debts to the City (are) current. (Sec 3-38)

If not, reasons _____

(7) A publisher's affidavit (has) been filed showing the notice requirement (has) been complied with. (Sec 3-40 (a))

(8) An affidavit from the applicant certifying posting of the proposed premises (has) been filed. (Sec. 3-40(b))

N/A

Respectfully submitted,

Megan Shea
City Clerk

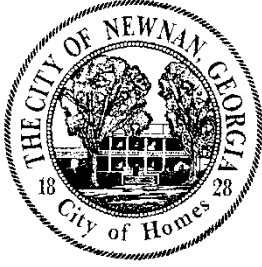

City of Newnan, Georgia - Mayor and Council

Date: January 11, 2022

Agenda Item: Consideration of amendment to Chapter 3, Alcoholic Beverages, of the Code of Ordinances of the City of Newnan, Georgia to amend Required Residency requirement.

Prepared and Presented by: Hasco Craver, Assistant City Manager

Purpose:

Newnan City Council may consider amending Chapter 3, Alcoholic Beverages, of the Code of Ordinances for the City of Newnan, Georgia to amend Sections 3-2 and 3-35.

More specifically, the proposed amendment will provide regulations for the licensing of licensees and licensed representatives, as defined, with an amended residency requirement. Currently, Section 3-2 and 3-35 define residency as a resident of Coweta County.

It is important to note that the residency requirement, as currently stated in Chapter 3, is not a state requirement. Instead, the Newnan City Council, when adopting the original ordinance in 1996, desired the licensee and/or licensed representative to be resident of Coweta County.

In amending the residency requirement, City staff, in consultation with the City Attorney, believes that the ordinance shall restate the residency requirement as follows: resident of the United States or a legal alien.

Funding: N/A

Recommendation:

Newnan City Council may amend Chapter 3, Alcoholic Beverages, of the Code of Ordinances of the City of Newnan, Georgia to amend certain Sections as described herein.

Attachments:

Ordinance to Amend Chapter 3, Alcoholic Beverages, of the Code of Ordinances of the City of Newnan, Georgia.

Previous Discussions with Council:

Newnan City Council, from time to time, has received informal updates from City staff related to the business community's desire to amend the residency requirement, as currently stated.

AN ORDINANCE TO AMEND CHAPTER 3, ALCOHOLIC BEVERAGES OF THE CODE OF ORDINANCES OF THE CITY OF NEWNAN, GEORGIA BY ELIMINATING THE REQUIREMENT THAT A LICENSEE BE A RESIDENT OF COWETA COUNTY AND ELIMINATE THE REQUIREMENT OF A LICENSE REPRESENTATIVE; AND FOR OTHER PURPOSES

WHEREAS, for the general welfare and continued growth and prosperity of the City of Newnan, the Mayor and City Council desire to amend Sec. 3-2, Definitions, Sec. 3-33, Supporting Document, Sec. 3-35, Required Residency license representative, Sec. 3-43, Renewal of License by City Clerk, Sec. 3-46 License transfers, change license representative or relocation of business of Chapter 3 of the City of Newnan Alcohol Beverage Ordinance to eliminate certain residency requirements for Licensees and eliminate the requirements for a License Representative for businesses selling and serving alcoholic beverages in the City of Newnan.

WHEREAS, the Mayor and City Council have determined that in addition to promoting business growth in the City of Newnan, it is important to the general welfare and prosperity of the City of Newnan to assist in the economic development of the City of Newnan by attracting new businesses and maintaining existing businesses in the City of Newnan by allowing for a revision to the residency requirements of both Licensees and License Representatives and to provide for more ease of applying for an alcoholic beverage license in order to maintain business opportunities for all businesses operating in the City of Newnan.

NOW, THEREFORE, BE IT ORDAINED AND IT IS HEREBY ORDAINED BY THE AUTHORITY OF THE MAYOR AND CITY COUNCIL OF THE CITY OF NEWNAN AS FOLLOWS:

Section 1: Article I, in General, Sec. 3-2, Definitions, of Chapter 3 Alcoholic Beverages of the City’s Code of Ordinances is hereby amended by deleting the definition of Licensee in its entirety and adopting the following definition of Licensee to read as follows:

- Licensee:* The licensee for all businesses shall be:
- (1) The licensee shall be at least 21 years of age.
 - (2) If the business is to be operated by an individual, the licensee shall be that individual.
 - (3) If the business is to be operated by a partnership, the licensee shall be an individual who is a partner; or, if all partners are non-individuals, then the licensee shall be an individual who is an officer of any corporation which is a partner, or an individual who is an

officer, manager or agent of any unincorporated entity which is a partner.

- (4) If the business is to be operated by a corporation, the licensee shall be an officer of the corporation.
- (5) If the business is to be operated by a limited liability company the licensee shall be an individual who is a member, officer or manager of the limited liability company.

Section 2: Article I, in General, Sec. 3-2 Definitions, of Chapter 3 Alcoholic Beverages of the City's Code of Ordinances is hereby amended by deleting the definition of License Representative in its entirety.

Section 3: Article II, Licensing, Sec. 3-33, Supporting documents to be filed with application, of Chapter 3, Alcoholic Beverages of the City's Code of Ordinances is hereby amended by deleting, in their entirety, Paragraph (5) and Paragraph (6) and adopting a new Paragraph (5) to read as follows:

- (5) An affidavit that he/she is at least 21 years of age.

Section 4: Article II, Required residency, license representative, Sec. 3-35, Supporting documents to be filed with application, of Chapter 3, Alcoholic Beverages of the City's Code of Ordinance is hereby deleted in its entirety and the word (Reserved) is hereby inserted thereby.

Section 5: Article II, Sec. 3-43, Renewal of license by city clerk, of Chapter 3, Alcoholic Beverages of the City's Code of Ordinance is hereby amended by deleting the words "or license representative" in Paragraph (7).

Section 6: Article II, Sec. 3-46, License transfers, change licensee or license representative, or relocation of the business of the City's Code of Ordinances is hereby amended by deleting the words "or license representative" in the section heading and in Paragraph (b) sub-paragraph (1) by deleting the words "or license representative" and in Paragraph (d) by deleting the words "and license representative".

Section 7: Article II, Sec. 3-46, License transfers, change licensee, or relocation of the business of the City's Code of Ordinances, Paragraph (c)(1)(2)(3)(4)(5) in its entirety and the word (Reserved) is hereby inserted thereby.

Section 8: Repealer. All ordinances in conflict with the provisions of this ordinance are hereby repealed.

Section 9: Constitutionality. Should any phrase, clause, sentence of this Ordinance be deemed unconstitutional by a Court of competent jurisdiction, such determination shall not affect the remaining provisions of this Ordinance which provisions shall remain in full force and effect.

Section 10 Limitation. Adoption of this Ordinance does not create any additional right or benefit, substantive or procedural, enforceable in law or in equity by any party against the City of Newnan, its departments, agencies, officials, employees, agents or other person or entity.

Section 11: Effective Date. This Ordinance shall be effective immediately upon adoption.

DONE, RATIFIED AND PASSED in regular session, on second reading this the
____ day of _____, 2022.

ATTEST:

L. Keith Brady, Mayor

Megan Shea, City Clerk

Rhodes H. Shell, Mayor Pro-Tem

REVIEWED AS TO FORM:

C. Bradford Sears, Jr., City Attorney

George M. Alexander, Councilmember

Cleatus Phillips, City Manager

Cynthia E. Jenkins, Councilmember

Raymond F. DuBose, Councilmember

Dustin Koritko, Councilmember

Paul Guillaume, Councilmember



City of Newnan, Georgia - Mayor and Council

Date: January 11, 2022

Agenda Item: Consideration of Construction Contract Award, Budget and Funding for City Hall Reception Desk

Prepared and presented By: Hasco Craver, Assistant City Manager

Purpose:

Newnan City Council may consider awarding a construction contract to Tomco Construction for the construction of a reception desk at Newnan City Hall. In addition, Newnan City Council may consider approving the project budget.

Background:

As the City of Newnan's organization continues to grow and develop into a forward facing and technologically proficient public service agency, it has become apparent to senior City Staff that the need to provide a general reception service for our citizenry is of paramount importance.

The City of Newnan, not unlike many other organizations operating in an increasingly changing customer-focused environment, must continue to provide an exemplary level of personal service. More specifically, citizens and visitors alike are communicating with the City of Newnan at an alarmingly growing rate. There is an expressed need to house a receptionist to better provide intentionally clear and accurate information for those interested in the services provided by the City of Newnan (i.e. sanitation, planning, permitting, licensing, etc.).

City staff, in response to the stated need to provide dedicated customer services, enlisted the support of Houser Walker Architecture to develop design documents that will accommodate a professional receptionist area at Newnan City Hall. Please note that the proposed design will incorporate elements of the existing architecture found at the first floor of Newnan City Hall. Please find a copy of the proposed improvements attached herein.

Upon the development of design documents, City Staff solicited and secured several cost estimates/quotes from capable construction companies. Due to the anticipated cost of improvements and in accordance with the City's adopted Procurement Policy, City Staff prepared and released a Request for Proposals (RFP) for Professional Construction Services – Newnan City Hall Reception Area on December 1, 2021.

The City of Newnan received one proposal on December 21, 2021.

The following firm submitted a qualified proposal:

1. Tomco Construction
1040 Sullivan Road
Newnan, GA 30265

The recommendation herein is primarily based upon the following elements:

- Firm’s understanding of the project; and
- Firm’s availability and project approach; and
- Firm’s experience performing similar services; and
- Firm’s fee proposal

After close evaluation of the proposal and evaluation of the overall project funding needs, it is the recommendation of City staff, that a total project budget be set as shown below.

Construction Contract	\$69,000
Furniture, Fixture & Equipment	\$15,000
Owner Contingency	\$5,000
Total Recommended Budget	\$89,000

Funding:

General Fund

Recommendation:

City staff recommends that the New City Council award the construction contract the Tomco Construction in the amount of \$69,000. In addition, City Staff recommends that the Newnan City Council consider and approve a total project budget of \$89,000 (project budget details above).

Attachment:

1. Design Documents

Previous Discussion with Council:

Newnan City Council, during the FY 2022 Budget Public Hearing on December 14, 2021, received a presentation which described the proposed addition of a reception area and staff.

PROJECT NAME:

NEWNAN CITY HALL



Salvage existing countertop for reuse

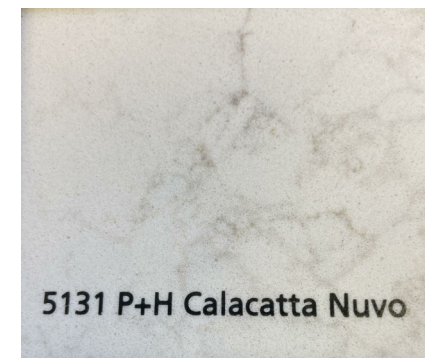

Additional countertop - Quartz, caesarstone, 5131 p+h calcatta nuvo



Wooden Slats, match existing species and color of existing wood

1819 Peachtree Road, NE
Suite 102
Atlanta, GA 30309
404.633.4264
houserwalker.com

Civil Engineer:
CIVIL FIRM NAME
Address 1
Address 2
XXX.XXX.XXXX
Contact: Name

Structural Engineer:
STRUCTURAL FIRM NAME
Address 1
Address 2
XXX.XXX.XXXX
Contact: Name

M.E.P. Engineer:
M.E.P. FIRM NAME
Address 1
Address 2
XXX.XXX.XXXX
Contact: Name

AV Consultant:
AV FIRM NAME
Address 1
Address 2
XXX.XXX.XXXX
Contact: Name

Interior Designer:
INTERIOR FIRM NAME
Address 1
Address 2
XXX.XXX.XXXX
Contact: Name

This document compliments and supports all other Project drawings, specifications and information that collectively express the design intent for the Project. This document is an Instrument of Service and represents creative work performed by Houser Walker Architecture and its consultants. Houser Walker Architecture and its consultants are the authors and owners of this Instrument of Service and retain all common law, statutory, and other reserved rights, including copyrights.

The Owner, Contractor, Subcontractors, Sub-subcontractors, and suppliers are authorized to use and reproduce this Instrument of Service solely and exclusively for the execution of this Project. This Instrument of Service can not be used for any purposes other than the execution of the scope of the Work without the specific written consent of Houser Walker Architecture and its consultants.

Copyright:
Houser Walker Architecture, 2021

SEAL:

Sheet Title: **COVER SHEET**
Author
Project Title: **NEWNAN CITY HALL - AND PUBLIC WORKS**
25 LaGrange Street, Newnan, Georgia 30263

Scale:
Issue:
DESIGN
Project Number: 2134
Date:
Current Revision:

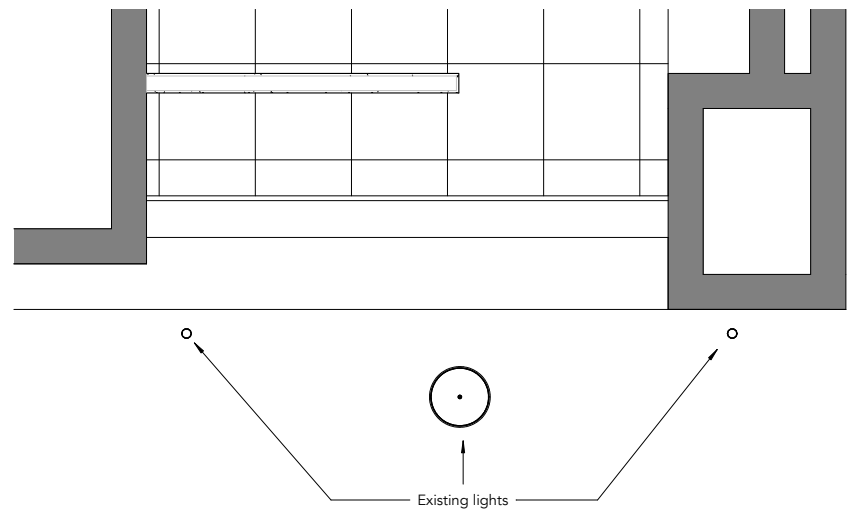

B5 RCP

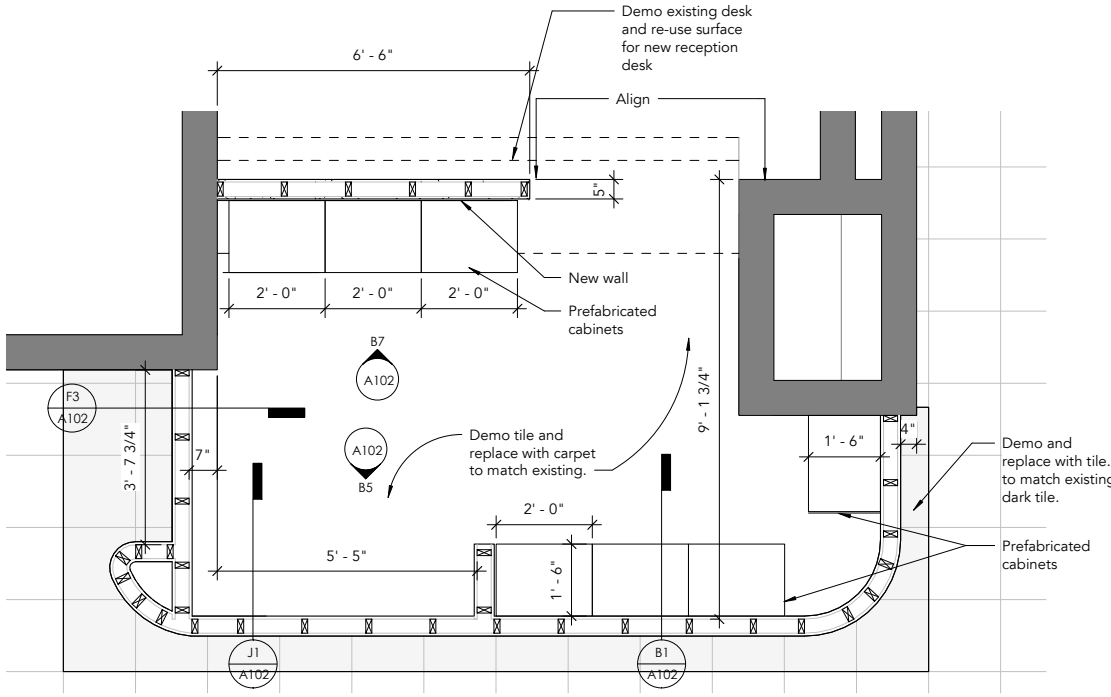

H4 Framing Plan

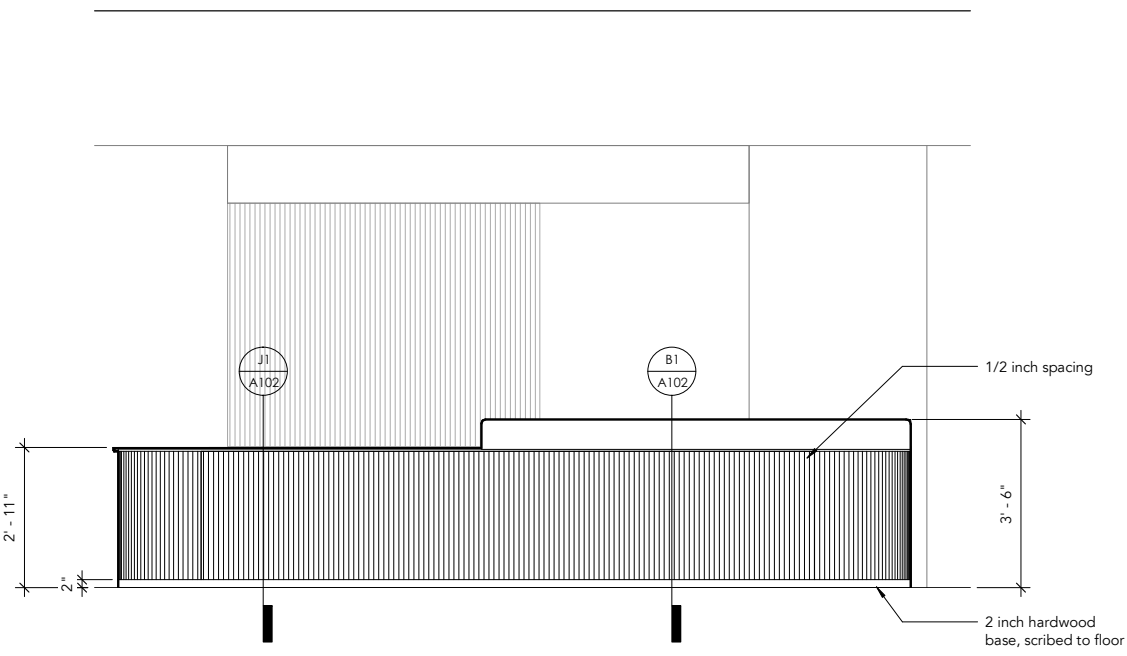

A1 Reception - North Front Elevation

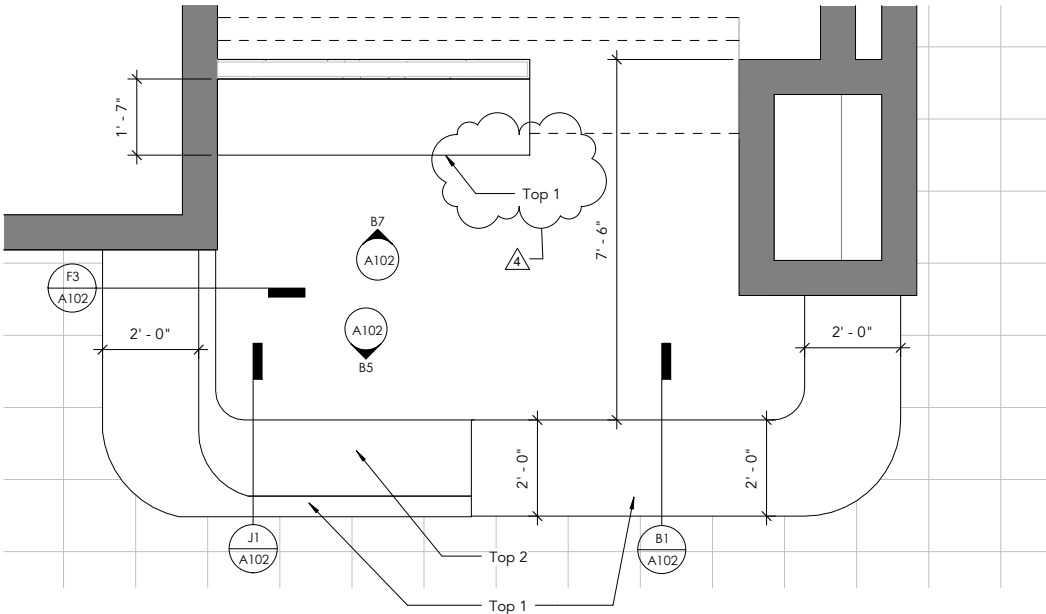

H1 Plan -Reception Desk

MATERIAL KEYNOTES

Top 1 - Caesarstone, Quartz, caesarstone, 5131 p+h calcatta nuovo, 2cm
 Top 2 - Reuse existing black marble

DRAWING LEGEND

- To be Removed
- Existing to Remain
- New Construction

GENERAL NOTES

SHEET-SPECIFIC NOTES

1819 Peachtree Road, NE
 Suite 102
 Atlanta, GA 30309
 404.533.4244
 houserwalker.com

This document compliments and supports all other Project drawings, specifications and information that collectively express the design intent for the Project. This document is an Instrument of Service and represents creative work performed by Houser Walker Architecture and its consultants. Houser Walker Architecture and its consultants are the authors and owners of this Instrument of Service and retain all common law, statutory, and other reserved rights, including copyrights.

The Owner, Contractor, Subcontractors, Sub-subcontractors, and suppliers are authorized to use and reproduce this Instrument of Service solely and exclusively for the execution of this Project. This Instrument of Service can not be used for any purposes other than the execution of the scope of the Work without the specific written consent of Houser Walker Architecture and its consultants.

Copyright:
 Houser Walker Architecture, 2021

SEAL:

Scale:

Issue:
DESIGN

Project Number: 2134
 Date: 08/03/21

Current Revision:
 Date RFI #x

SHEET NO:

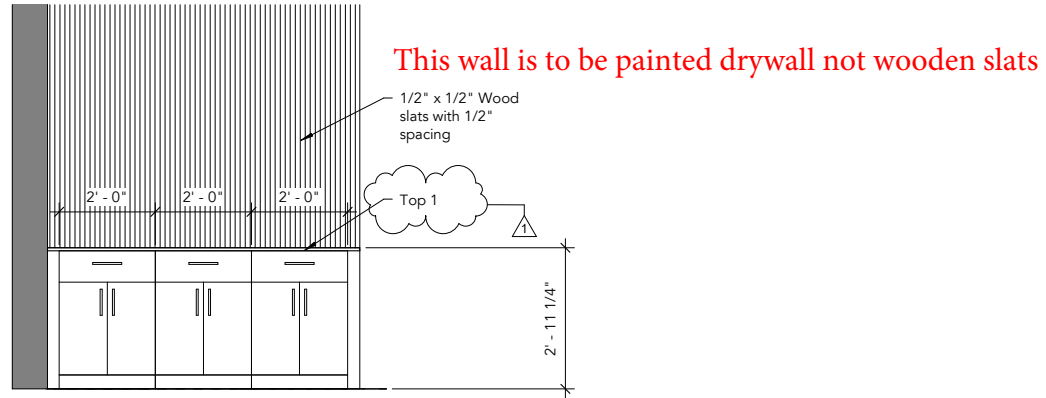

B7 Back Wall

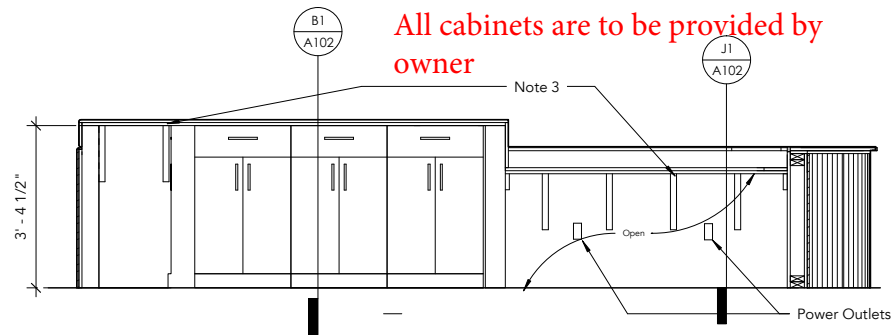

B5 Reception - South Back Elevation

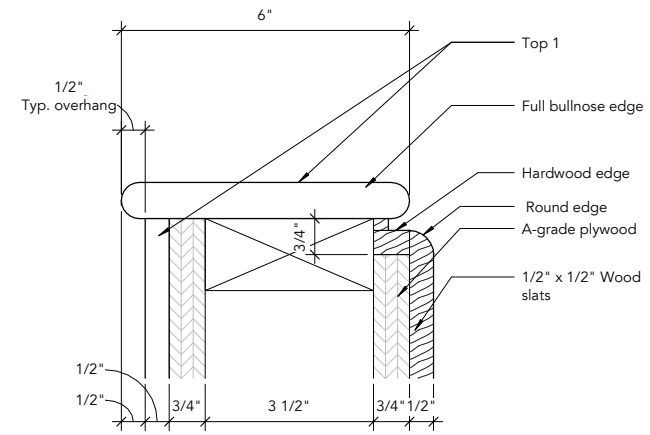

J5 Countertop Detail

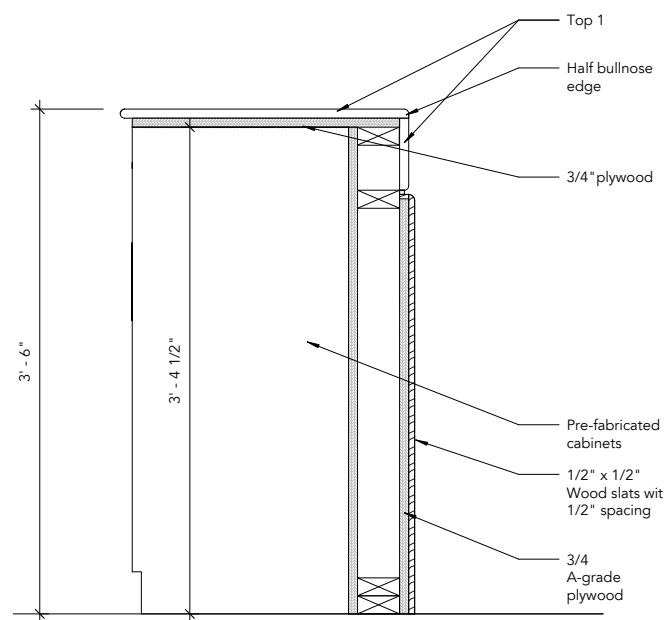

B1 Detail Higher Desk

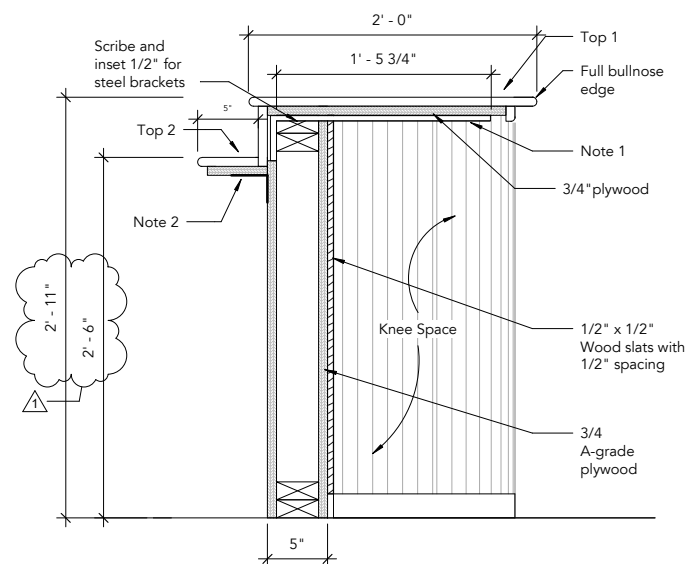

F3 Detail Side

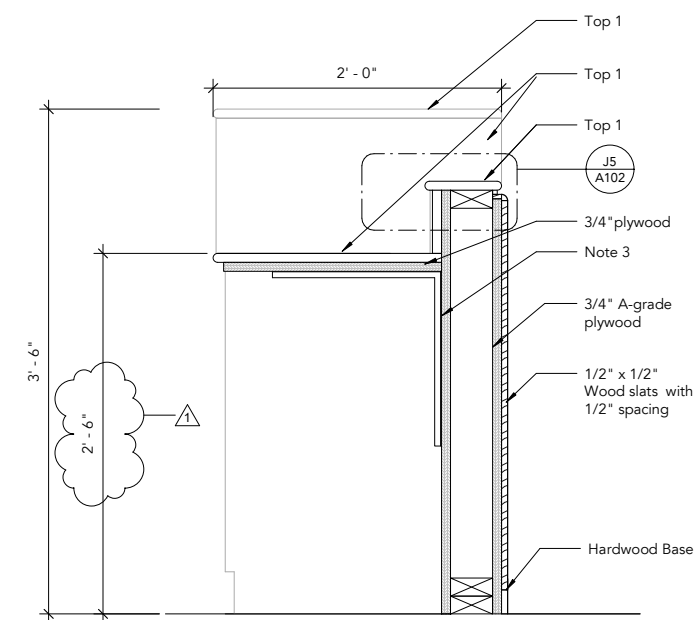

J1 Detail Lower Desk

MATERIAL KEYNOTES

Top 1 - Caesarstone, Quartz, caesarstone, 5131 p+h calcatta novo, 2cm
 Top 2 - Reuse existing black marble

GENERAL NOTES

SHEET-SPECIFIC NOTES

- Note 1
1/2" thick, 2"W X 18"D x 4"H, hidden support solid steel heavy duty bracket, powder coated black by Ekena Millwork
- Note 2
1/2" thick, 2"W x 3"W x 4"H, steel bracket, powder coated black
- Note 3
2" W x 14" D x 14"H Hamilton Steel Bracket, Powder Coated Black, align with studs, Ekena Millwork

This document compliments and supports all other Project drawings, specifications and information that collectively express the design intent for the Project. This document is an Instrument of Service and represents creative work performed by Houser Walker Architecture and its consultants. Houser Walker Architecture and its consultants are the authors and owners of this Instrument of Service and retain all common law, statutory, and other reserved rights, including copyrights.

The Owner, Contractor, Subcontractors, Sub-subcontractors, and suppliers are authorized to use and reproduce this Instrument of Service solely and exclusively for the execution of this Project. This Instrument of Service can not be used for any purposes other than the execution of the scope of the Work without the specific written consent of Houser Walker Architecture and its consultants.

Copyright:
 Houser Walker Architecture, 2021

SEAL:

Scale:

Issue: **DESIGN**

Project Number: 2134 Date: 05/20/20

Current Revision: 11/09/21
 Revision 1

SHEET NO:



City of Newnan, Georgia - Mayor and Council

Date: January 11, 2022

Agenda Item: Consideration of Contract Award for Storm Debris Clean-up on City Owned Property

Prepared By: Ray Norton, Public Works Director

Purpose: Newnan City Council may consider a contract award for Storm Debris Clean-up of City owned properties.

Background: On November 4th an RFP was released for Storm Debris Clean-Up Services to remove storm damaged tree debris from 20.5 acres. of City owned property that was the result of the March 2021 EF4 Tornado. The estimated damage area within the 20.5 acres is roughly 10.6 acres.

There has been tremendous effort within the community with storm debris clean-up from their property and in conjunction, the City feels the need to make the same efforts on City Owned property as part of the progress of bringing our community back to pre-storm condition. Although this will take considerable time, staff feels that this contract will assist the City in this continuous effort. The aforementioned property includes road frontage on East Broad Street, Pinson Street, Savannah Street and Smith Street.

Proposals were due December 7, 2021 at 10AM EST with the following firm submitting a total amount of \$220,533. No other proposals were received.

Piedmont Paving
1226 Highway 16 East
Newnan, Georgia 30263

Funding: General Fund

Recommendation: Staff recommends awarding the contract to Piedmont Paving for a total amount of \$220,533.00.

Previous Discussion with Council: City Council has been greatly supportive of all storm cleanup efforts as staff has brought forth since March 26, 2021.



City of Newnan, Georgia

**BID OPENING: Storm Debris Clean-up (City Properties)
Tuesday December 7, 2021 – 10:00 A.M.**

BIDDER	BID AMOUNT	COMMENTS
<i>Piedmont Paving, Inc.</i>	<i>\$220,533</i>	
<i>[REDACTED]</i>		

Georgen Alexander

BIDS OPENED BY _____

Ry DeBa

Newnan Property Area - Substation

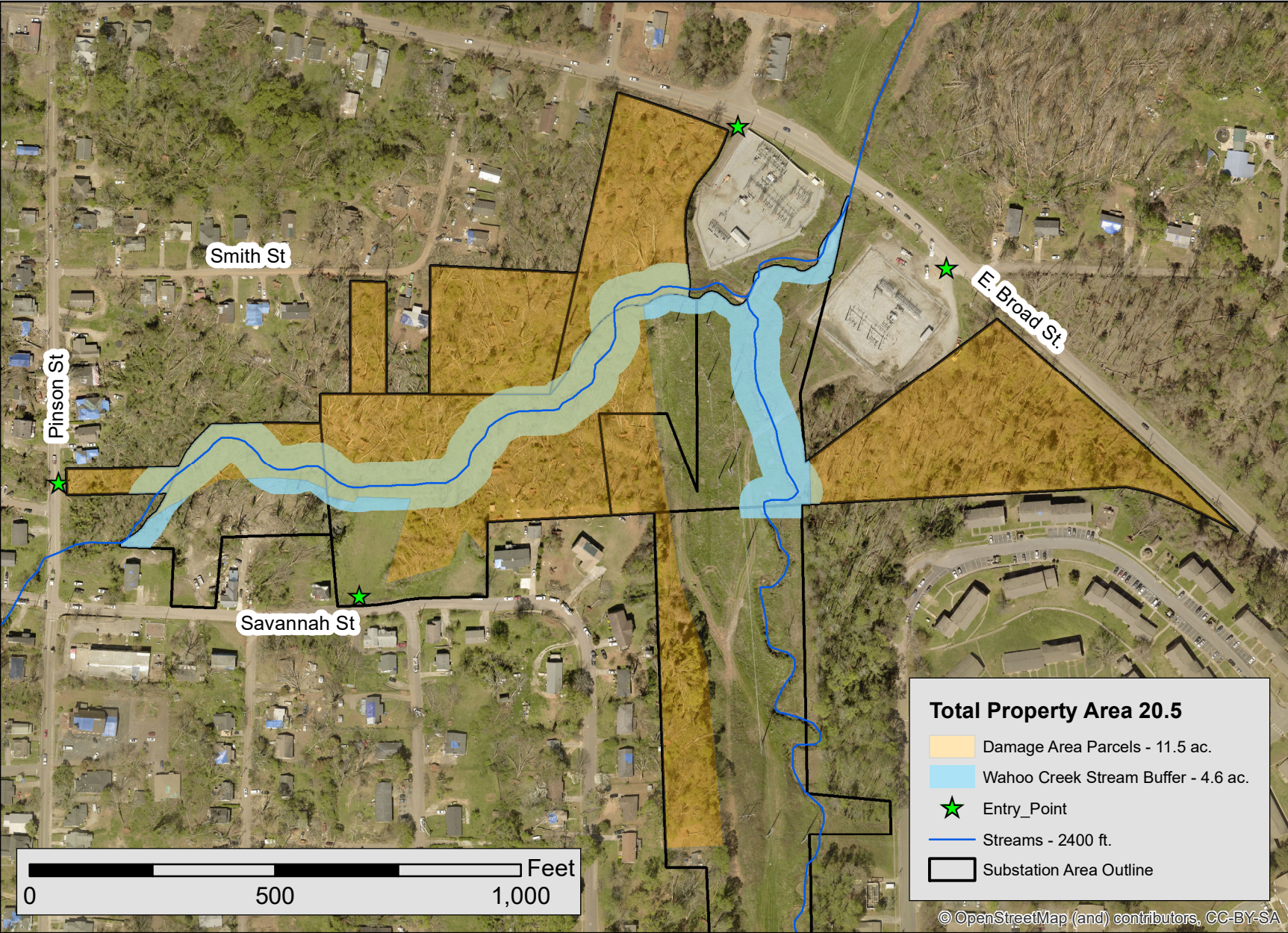



City of Newnan, Georgia - Mayor and Council

Date: January 11, 2022

Agenda Item: Request to Abandon Public Right of Way

Prepared By: Michael Klahr, Director of Engineering

Purpose: The Council may consider the abandonment of certain unimproved public Right of Way, referred to as Highland Avenue, running perpendicular to Joe P Norman Boulevard, near private street, Barron Court.

Background: The property owners of the lot at 35 Joe P Norman Boulevard have approached the City with a request to abandon unimproved public Right of Way to them, referred to as Highland Avenue, adjacent to their lot.

The unimproved public Right of Way also abuts the parcel addressed as 56 Sewell Road (Free & Accepted Masons).

At this time, the request by the owners of 35 Joe P Norman is for, at a minimum, one half of the unimproved Public Right of Way for Highland Avenue.

Funding: N/A

Recommendation: Begin the process for abandonment of public Right of Way in accordance with Part 1, Article VI, and Section 6.23 of the Code of Ordinances for the City of Newnan for the sale of City property.

Attachments: Letter of Request
Location map

To Whom It May Concern,

12/8/2020

Our names are Kirk Avery and James Legan. We own the lot at 35 Joe Norman Newnan, Ga 30263. We are requesting to have the City of Newnan abandon the unopened road "Highland Avenue" perpendicular to Joe Norman and to the south of our property so we may purchase a minimum of 50% of the abandoned road.

This would allow us enough linear feet of road frontage on Joe Norman to build two single family homes. We also own the house across the street at 36 Joe Norman.

Regards,

Kirk Avery and James Legan

PO Box 1015

Newnan, Ga 30264

770 301-1889

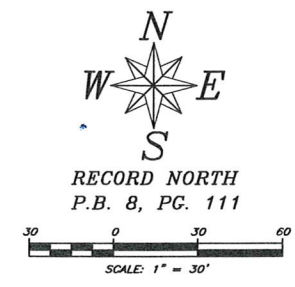

SURVEY DATA:
 TOTAL AREA: 0.50 ACRES
 PLAT CLOSURE:
 E.O.C. PLAT: 1" IN 145,599 FEET
 FIELD CLOSURE:
 E.O.C. FIELD: 1" IN 32,033 FEET
 ANGULAR ERROR: 2" PER ANGLE POINT
 ADJUSTED BY: COMPASS RULE
 EQUIPMENT USED:
 Trimble Z600: 90 ROBOTIC TOTAL STATION
 REFERENCES:
 D.B. 3850, PG. 755
 D.B. 7, PG. 372
 P.B. 28, PG. 37
 P.B. 17, PG. 125
 P.B. 8, PG. 111
 CURRENT OWNER:
 JAMES LEDAN & KIRK AVERY
 313 DAVENPORT DRIVE
 SUITE 101
 PEACHTREE CITY, GA 30269
 PROPERTY ADDRESS:
 35 JOE P. NORMAN BLVD.
 NEWNAN, GEORGIA 30263



LEGEND
 ○ IRON PIN SET, SIZE/TYPE NOTED
 ● IRON PIN FOUND, SIZE/TYPE NOTED
 --- FENCE
 --- SUBJECT PROPERTY LINE
 --- ADJACENT PROPERTY LINE
 --- RIGHT OF WAY
 --- PARCEL NUMBER
 --- PLAT BOOK
 --- DEED BOOK
 --- PAGE
 --- SQUARE FEET
 --- ACRES
 --- ERROR OF CLOSURE
 --- NOT TO SCALE
 --- RIGHT OF WAY
 --- BUILDING LINE
 --- 3/8" REBAR
 --- OPEN TOP PIPE FOUND

- GENERAL NOTES:**
1. THE CERTIFICATION, AS SHOWN HEREON, IS PURELY A STATEMENT OF PROFESSIONAL OPINION BASED ON KNOWLEDGE, INFORMATION AND BELIEF, AND BASED ON EXISTING FIELD EVIDENCE AND DOCUMENTARY EVIDENCE AVAILABLE. THE CERTIFICATION IS NOT AN EXPRESSED OR IMPLIED WARRANTY OR GUARANTEE.
 2. THIS SURVEY COMPLIES WITH BOTH THE RULES OF THE GEORGIA BOARD OF REGISTRATION FOR PROFESSIONAL ENGINEERS AND LAND SURVEYORS AND THE OFFICIAL CODE OF GEORGIA ANNOTATED (OCGA) 15-6-67 AS AMENDED BY HB 76 (2017), IN THAT WHERE A CONFLICT EXISTS BETWEEN THOSE TWO SETS OF SPECIFICATIONS, THE REQUIREMENTS OF LAW PREVAIL.
 3. THIS PLAT IS FOR THE EXCLUSIVE USE OF THE PARTIES NAMED IN THE TITLE BLOCK AND OR THE CERTIFICATION. ANY USE BY OTHER PARTIES NOT NAMED IS AT THEIR OWN RISK.
 4. THIS PLAT IS NOT VALID UNLESS IT BEARS THE ORIGINAL SIGNATURE OF THE REGISTRANT ACROSS THE REGISTRANT'S SEAL IN CONTRASTING INK.
 5. IN MY OPINION, THIS PROPERTY DOES NOT LIE WITHIN A SPECIAL FLOOD HAZARD AREA AS DEFINED BY F.E.M.A. FLOOD INSURANCE RATE MAPS (FIRM) #13077002310 WITH EFFECTIVE DATE OF FEBRUARY 6, 2013.
 6. THIS SURVEY WAS PREPARED WITHOUT THE BENEFIT OF AN ABSTRACT TITLE; THEREFORE, THE UNDERSIGNED AND CHRISTOPHER BROTHERS / GASKINS MAKE NO GUARANTEES OR REPRESENTATIONS REGARDING INFORMATION SHOWN HEREON PERTAINING TO EASEMENTS, RIGHT-OF-WAY, SETBACK LINES, AGREEMENTS, RESERVATIONS, AND OTHER SIMILAR MATTERS.
 7. BASE BEARING TAKEN FROM P.B. 8, PG. 111. ALL OTHER BEARINGS CALCULATED FROM ANGLES TURNED.
 8. CURRENTLY ZONED RML.
 9. INFORMATION REGARDING THE REPUTED PRESENCE, SIZE, CHARACTER AND LOCATION OF EXISTING UNDERGROUND UTILITIES AND STRUCTURES IS SHOWN HEREON. THERE IS NO CERTAINTY OF THE ACCURACY OF THIS INFORMATION AND IT SHALL BE CONSIDERED IN THAT LIGHT BY THOSE USING THIS DRAWING. THE LOCATION AND ARRANGEMENT OF UNDERGROUND UTILITIES AND STRUCTURES, SHOWN HEREON, MAY BE INACCURATE AND UTILITIES AND STRUCTURES NOT SHOWN MAY BE ENCOUNTERED. THE OWNER, HIS EMPLOYEES, HIS CONSULTANTS, HIS CONTRACTORS, AND/OR HIS AGENTS SHALL HEREBY DISTINCTLY UNDERSTAND THAT THE SURVEYOR IS NOT RESPONSIBLE FOR THE CORRECTNESS OR SUFFICIENCY OF THIS INFORMATION, SHOWN HEREON, AS TO SUCH UNDERGROUND INFORMATION.

SURVEYOR'S CERTIFICATION:

This plat is a retracement of an existing parcel or parcels of land and does not subdivide or create a new parcel or make any changes to any real property boundaries. The recording information of the documents, maps, plats, or other instruments which created the parcel or parcels are stated hereon. RECORDATION OF THIS PLAT DOES NOT IMPLY APPROVAL OF ANY LOCAL JURISDICTION, AVAILABILITY OF PERMITS, COMPLIANCE WITH LOCAL REGULATIONS OR REQUIREMENTS, OR SUITABILITY FOR ANY USE OR PURPOSE OF THE LAND. Furthermore, the undersigned land surveyor certifies that this plat complies with the minimum technical standards for property surveys in Georgia as set forth in the rules and regulations of the Georgia Board of Registration for Professional Engineers and Land Surveyors and as set forth in O.C.G.A. Section 15-6-67.

12/02/2021
 CHRIS W. ROBERTSON GA RLS #3195 DATE:



DRAWN BY: VGB
CHECKED BY: CWR
FIELD DATE: 09/13/2021
OFFICE DATE: 12/02/2021
REVISIONS

Gaskins
 ENGINEERING SURVEYING PLANNING CONSULTING CONSTRUCTION MGMT

Christopher Brothers
 www.gasurvey.com LSP# 789
 24 Jackson Street, Newnan, GA 30263
 Phone: (770) 253-5195

811 Know what's below.
 Call before you dig.

UTILITY PROTECTION CENTER
 CALL 811 FREE:
 THREE WORKING DAYS BEFORE YOU DIG.

BOUNDARY SURVEY
 FOR
 KIRK AVERY
 LOTS 1-3, BLOCK D

LOCATED IN L.L. 9
 2ND DISTRICT,
 COWETA COUNTY, GEORGIA

Drawing name: K:\L\B02\Gaska\1212-0029\15 JOE P. NORMAN BLVD (Area)\DWG\15 JOE P. NORMAN BLVD.dwg
 Printed by: cwh
 Date: 12/02/2021 12:44pm

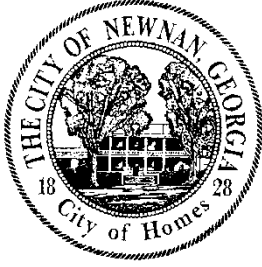

City of Newnan, Georgia - Mayor and Council

Date: January 11, 2022

Agenda Item: Consideration of an Agreement between the City of Newnan, Georgia and the Friends of LINC, Inc. to support and promote the LINC multi-use trail in Newnan, Georgia

Prepared and Presented by: Hasco Craver, Assistant City Manager

Purpose: Newnan City Council may consider an Agreement between the City of Newnan, Georgia and the Friends of LINC, Inc. to support and promote the LINC multi-use trail in Newnan, Georgia.

Background: Newnan City Council, beginning in 2019, entered into a three year joint agreement with the Friends of LINC, Newnan Utilities and Coweta Fayette EMC to support the promotion and development of the LINC in Newnan, Georgia.

The agreement, as presented, contemplates a new three year term with two partners: the City of Newnan and the Friends of LINC.

City staff, in consultation with the board of the Friends of LINC, believes that the modified agreement will allow the Friends of LINC to maintain certain initiatives that are beneficial to the successful promotion of the LINC multi-use trail system. In particular, the agreement has a narrowed focus primarily centered on the enhancement of public engagement and increasing awareness of the LINC in our community.

Please note the following:

- The City of Newnan will fund the Friends of LINC, Inc. for three years (2022-2024); and
- The City of Newnan will fund \$15,000 per annum; and
- The City of Newnan will appoint a staff member as an ex-officio advisory member to the Friends of LINC Board; and
- The Friends of LINC will provide financial and personnel support for the promotion of the LINC; and
- The Friends of LINC will maintain its responsibility of raising funds and spending funds to support the LINC multi-use trial system, consistent with its stated mission

Funding:

General Fund

Recommendation: In an effort to maintain the success of the Friends of the LINC, City staff recommends approval of the Agreement between the City of Newnan, Georgia and the Friends of LINC, Inc.

Attachments:

1. Agreement between the City of Newnan, Georgia and the Friends of LINC, Inc. to support and promote the LINC multi-use trail in Newnan, Georgia

Previous Discussions with Council:

The City of Newnan, beginning in 2019, has maintained an agreement with the Friends of LINC, Inc.

GEORGIA COWETA COUNTY

THIS AGREEMENT, made and entered into this ___ date of _____, 2022, by and between the City of Newnan, Georgia, hereinafter called “City”, and the Friends of LINC, Inc., A Georgia non-profit corporation, hereinafter called “FOL”.

WITNESSETH:

WHEREAS, the governing bodies of the City and FOL are mutually interested in building, maintenance, usage and enhancement for the LINC multi-use trail system; and

WHEREAS, said City and FOL are authorized to enter into an agreement convenient to and cooperate in providing for adequate activities and programs for the LINC multi-use trail system.

NOW, THEREFORE, in consideration of the premises, said City and FOL agree to cooperate with each other in carrying out the above purpose, and to that end agree as follows:

1. The City agrees as follows:

- a) To fund \$15,000.00 per annum for the fiscal years 2022-2024 to FOL for normal business services; and
- b) To appoint a City staff member as an ex-officio advisory member to the FOL

2. FOL agrees as follows:

- a) To provide financial and personnel support for promotional activities and programs for enhancement, resource development, public engagement and increased awareness of the LINC multi-use trail; and
- b) To hold the primary responsibility for accepting funds or contributions to operate the FOL program, and to ensure that tax deductible gifts of land, right-of-way or rights for the purpose of extension of the LINC multi-use trail system will be promptly conveyed to the City and to use funds and contributions raised by FOL consistent with its mission;

3. This agreement will expire at midnight December 31, 2024 unless terminated sooner. City or FOL may terminate this Agreement at any time for its convenience by giving the other party thirty (30) days written notice of its intention to so terminate.

IN WITNESS WHEREOF, and pursuant to the authority granted by duly recorded resolutions, the parties hereto have caused this agreement to be executed on their behalf.

CITY OF NEWNAN

ATTEST:

By: _____
Mayor

City Clerk

REVIEWED AS TO FORM:

City Manager

REVIEWED AS TO FORM;

City Attorney

Friends of LINC, INC.

By: _____

**SANDERS, HAUGEN, & SEARS, P.C.
ATTORNEYS AT LAW
11 PERRY STREET
P. O. BOX 1177
NEWNAN, GEORGIA 30264-1177
(770) 253-3880
FAX (770) 254-0093**

**C. BRADFORD SEARS, JR.
E-MAIL: bsears@sandershaugen.com**

**WALTER D. SANDERS
(1909 - 1989)
WILLIS G. HAUGEN
(1929 - 2014)**

TO: Mayor and City Council
City of Newnan

FROM: C. Bradford Sears, Jr.
City Attorney, City of Newnan

CC: Cleatus Phillips, City Manager, City of Newnan
Dennis McEntire, General Manager, Newnan Utilities
Jeff Phillips, Assistant General Manager, Newnan Utilities
Bill Stemberger, Esq, Attorney for Newnan Utilities

DATE: December 1, 2021

RE: Sale of Assets of Georgia Public Web, Inc.

MEMORANDUM

MEAG and Georgia Public Web, Inc. created in 1996 of which the City is a member, has determined that it is in the best interest of the participants to sell the assets of Georgia Public Web, Inc.

Attached are the following:

- (1) Execution of the Written Consent included in this package which authorizes GPW to execute the Asset Purchase Agreement without a formal meeting of its Members; and
- (2) Execution of the proposed Amendment to the Telecom Contract with MEAG Power which will allow MEAG Power to agree to the sale of any remaining Telecom Assets to the purchaser; and
- (3) Resolution Regarding Approval of the Sale of Assets of Georgia Public Web, Inc.; and
- (4) Resolution Regarding Distribution of Monies From the Sale of Assets of Georgia Public Web, Inc.

Let me know if you have any questions.

RESOLUTION AUTHORIZING THE EXECUTION, DELIVERY AND PERFORMANCE OF THE FOURTH AMENDMENT TO TELECOMMUNICATIONS PROJECT CONTRACT WITH THE MUNICIPAL ELECTRIC AUTHORITY OF GEORGIA; AND FOR OTHER PURPOSES

WHEREAS, City of Newnan (the “Participant”) has entered into a Telecommunications Project Contract, dated as of May 1, 1996, with the Municipal Electric Authority of Georgia (“MEAG Power”), as amended by a First Amendment to Telecommunications Contract, dated as of February 1, 1997, a Second Amendment to Telecommunications Contract, dated as of June 1, 1997, and a Third Amendment to Telecommunications Contract, dated as of January 1, 2008; and,

WHEREAS, in order to effect certain changes to the Telecommunications Contract, the Participant has determined to enter into a Fourth Amendment to the Telecommunications Contract with MEAG Power (the “Fourth Amendment”);

NOW, THEREFORE, BE IT RESOLVED that the [Mayor/Chairman] is hereby authorized and directed to execute and perform, and the [Clerk/Secretary], or any Assistant [Clerk/Secretary], is hereby authorized to attest deliver the Fourth Amendment, in substantially the form thereof that has been attached hereto and filed in the Minute Book of the Participant; and

FURTHER RESOLVED that the Participant hereby authorizes the City of Newnan and the [Clerk/Secretary], or any Assistant [Clerk/Secretary], to take any further actions and execute and deliver any other documents necessary to carry out the purpose of this Resolution and the Fourth Amendment, as amended from time to time.

This the ___ day of _____, 2021.

CITY OF NEWNAN

[Mayor/Chairman]

ATTEST:

[Clerk/Secretary]

[SEAL]

EXHIBIT A
FOURTH AMENDMENT

,

CLERK/SECRETARY'S CERTIFICATE

I, the undersigned [Clerk/Secretary] of the City of Newnan (the "Participant"), DO HEREBY CERTIFY that the foregoing pages constitute a true and correct copy of a Resolution adopted by the Participant at an open public meeting duly and lawfully assembled in accordance with Official Code of Georgia Annotated Section 50-14-1, at which a quorum was present and acting throughout. The original of the Resolution has been duly recorded in the minute book of the Participant, which is in my custody and control.

WITNESS MY HAND this ____ day of _____, 2021.

[Clerk/Secretary]

(SEAL)

**FOURTH AMENDMENT TO
TELECOMMUNICATIONS PROJECT CONTRACT
BETWEEN
MUNICIPAL ELECTRIC AUTHORITY OF GEORGIA
AND
THE UNDERSIGNED PARTICIPANT**

This Fourth Amendment to the Telecommunications Project Contract, made and entered into as of _____, 2021, by and between the Municipal Electric Authority of Georgia, a public body corporate and politic, a public corporation and an instrumentality of the State of Georgia (the "Authority"), created by the provisions of Ga. L. 1975, p. 107 (codified at O.C.G.A. § 46-3-100, et seq.), as amended, and the undersigned political subdivision of the State of Georgia, hereinafter sometimes designed as the Participant (hereinafter, the "Fourth Amendment").

WITNESSETH:

WHEREAS, the Participant and the Authority have heretofore entered into a Telecommunications Project Contract, dated as of May 1, 1996 (the "Telecommunications Contract"), under which the Authority agreed to finance the cost of acquiring and constructing a Telecommunications System on behalf of those Participants executing Telecommunications Contracts, and

WHEREAS, the Participant and the Authority have heretofore entered into a First Amendment to Telecommunications Contract dated as of February 1, 1997, a Second Amendment to Telecommunications Contract dated as of June 1, 1997, and a Third Amendment to the Telecommunications Contract dated as of January 1, 2008, for the purposes stated in the respective documents (hereinafter "the Amended Telecommunications Project Contract"); and,

WHEREAS, the Amended Telecommunications Contract provides in Article III that the Authority “shall acquire, own, operate and maintain the Telecom Project in a prudent manner for the benefit of the Participants, and for the benefit of Project One”;

WHEREAS, the Authority entered into a Master Agreement dated January 23, 2001 with Georgia Public Web, Inc. (GPW), wherein the Authority granted to GPW the right to lease or otherwise utilize the assets comprising the Telecom Project in exchange for GPW agreeing to operate and maintain such assets for the benefit of the Participants in the Telecommunications Project and to assume such other obligations of the Authority;

WHEREAS, GPW’s Board, has approved, subject to the approval of its Members, an Asset Purchase Agreement with Macquarie Newco, LLC (hereinafter “Macquarie”) providing for a sale by GPW of substantially all of its assets, as described in the draft of the Asset Purchase Agreement provided by GPW to its Members for review and approval (hereinafter the Transaction);

WHEREAS, the Transaction, if approved by GPW Members, also requires a sale by MEAG Power of any remaining ownership interest in certain of the assets comprising the Telecommunications Project;

NOW, THEREFORE, it is agreed by and between the Parties hereto as follows:

Section 1. The Amended Telecommunications Contract is hereby further amended by adding the following additional Section:

Section 309. MEAG Power is authorized to sell those properties, telecommunication facilities, fibers and other equipment comprising the Telecommunications Project for which legal title is still held by MEAG Power as may be necessary to facilitate the Transaction. However, MEAG Power’s authority under this Section is

conditioned upon the GPW Members first approving the proposed Transaction.

Section 2. If any provision hereof shall be held invalid or unenforceable by any court of competent jurisdiction, such holding shall not invalidate or render unenforceable any other provision hereof or of the Telecommunications Contract.

Section 3. This Fourth Amendment to Telecommunications Contract may be executed in any number of counterparts, each of which shall be deemed to an original, but all of which together shall constitute one and the same instrument.

Section 4. This Fourth Amendment to Telecommunications Contract shall be governed by, and construed and enforced in accordance with, the laws of the State of Georgia.

Section 5. Except as otherwise specifically provided herein, all words and phrases utilized in this Fourth Amendment shall have the same meaning as the definitions of the terms contained in the Amended Telecommunications Contract, and, by this reference thereto, the same are incorporated herein.

IN WITNESS WHEREOF, the Municipal Electric Authority of Georgia has caused this Fourth Amendment to the Amended Telecommunications Contract to be executed in its corporate name by its duly authorized officer and the Authority has caused this Fourth Amendment to Telecommunications Contract to be executed in its corporate name by its duly authorized officer and its corporate seal to be hereunto impressed and attested, and delivery hereof by the Authority to the Participant is hereby acknowledged, on the date and year first above written.

**MUNICIPAL ELECTRIC AUTHORITY OF
GEORGIA**

By: _____
Name: James E. Fuller
Title: President & CEO

ATTEST:

By: _____
Name: _____
Title: _____

APPROVED AS TO FORM:

Peter M. Degan
Sr. Vice President & General Counsel

CITY OF NEWNAN

By: _____
Name: _____
Title: _____

ATTEST:

By: _____
Name: _____
Title: _____

APPROVED AS TO FORM:

City Attorney

**RESOLUTION
REGARDING APPROVAL OF THE
SALE OF ASSETS OF GEORGIA PUBLIC WEB, INC.**

WHEREAS, The Mayor and the City Council and The Board of Water, Sewerage and Light Commissioners of the City of Newnan have approved the execution of the Fourth Amendment to The Telecommunications Project Contract dated May 1, 1996 between the City of Newnan, The Board of Water, Sewerage and Light Commissioners of the City of Newnan and the Municipal Electric Authority of Georgia; and

WHEREAS, the Mayor and the City Council and The Board of Water, Sewerage and Light Commissioners of the City of Newnan need to approve the execution of the Written Consent of The Members of Georgia Public Web, Inc. to enter into the transaction set out in the Asset Purchase Agreement between the Corporation and the party name therein for the sale of the assets of Georgia Public Web, Inc.; and

NOW THEREFORE, BE IT RESOLVED and it is hereby resolved by the Mayor and City Council of the City of Newnan that the Mayor and City Clerk be authorized to execute the Written Consent of The Members of Georgia Public Web, Inc. authorizing the sale of the assets of Georgia Public Web, Inc. pursuant to the terms of the Asset Purchase Agreement referenced therein.

SO RESOLVED in open session, regularly assembled this ____ day of _____, 2022.

ATTEST:

Megan Shea, City Clerk

L. Keith Brady, Mayor

REVIEWED AS TO FORM:

C. Bradford Sears, Jr., City Attorney

Rhodes H. Shell, Mayor Pro-Tem

Cleatus Phillips, City Manager

George M. Alexander, Councilmember

Cynthia E. Jenkins, Councilmember

Raymond F. DuBose, Councilmember

Dustin Koritko, Councilmember

Paul Guillaume, Councilmember

**WRITTEN CONSENT
OF THE MEMBERS OF
GEORGIA PUBLIC WEB, INC.**

The undersigned, being members of Georgia Public Web, Inc., a nonprofit corporation organized and existing under the laws of the State of Georgia (the “**Corporation**”), pursuant to Section 14-3-704 of the Georgia Nonprofit Corporation Code and the Bylaws of the Corporation, hereby consent that the following actions be taken by the Corporation and that the following resolutions be adopted without the necessity of a formal or informal meeting by the Corporation and without the requirement of any notices of or materials with respect to such meeting for the purposes set forth hereafter, and hereby direct that this consent be delivered to the Corporation for inclusion in the minutes or filing with the corporate records.

RESOLVED, that the undersigned members of the Corporation hereby approve of the Corporation entering into the transactions substantially described in that certain Asset Purchase Agreement by and between the Corporation and other party named therein (the “**Agreement**”), a current copy of which is attached hereto as Exhibit A, and all other exhibits, documents and transactions related thereto or delivered therewith.

IN WITNESS WHEREOF, the undersigned do hereby give their consent to these resolutions.

[Signature pages attached]

**WRITTEN CONSENT
OF THE MEMBERS OF
GEORGIA PUBLIC WEB, INC.**

SIGNATURE PAGE

The City of Newnan, Georgia

By: _____
Name: _____
Title: _____

Date signed: _____

Membership percentage: 5.094%

**WRITTEN CONSENT
OF THE MEMBERS OF
GEORGIA PUBLIC WEB, INC.**

EXHIBIT A

Asset Purchase Agreement

ASSET PURCHASE AGREEMENT

by and between

[Macquarie Newco, LLC]

and

Georgia Public Web, Inc.

dated as of _____, 202_

Table of Contents

ARTICLE 1: DEFINITIONS	1
ARTICLE 2: PURCHASE AND SALE OF ASSETS	11
2.1 AGREEMENT TO PURCHASE AND SELL; ASSUMPTION	11
2.2 PURCHASED ASSETS	12
2.3 RETAINED ASSETS	13
2.4 ASSUMED LIABILITIES	14
2.5 RETAINED LIABILITIES.....	14
2.6 TRANSFER OF PURCHASED ASSETS OR ASSUMPTION OF ASSUMED LIABILITIES NOT EFFECTED AT THE CLOSING.....	16
ARTICLE 3: PURCHASE PRICE; ADJUSTMENT; ALLOCATION	17
3.1 PURCHASE PRICE	17
3.2 PURCHASE PRICE ADJUSTMENT	17
3.3 ALLOCATION	19
3.4 INVENTORY.....	20
ARTICLE 4: REPRESENTATIONS AND WARRANTIES OF THE SELLER.....	21
4.1 EXISTENCE; GOOD STANDING AND CAPITALIZATION	21
4.2 POWER.....	21
4.3 ENFORCEABILITY.....	21
4.4 NO CONFLICT	22
4.5 CONSENTS	22
4.6 PROPERTY.....	22
4.7 NECESSARY PROPERTY.....	23
4.8 PROCEEDINGS	23
4.9 COMPLIANCE WITH LAWS.....	23
4.10 CONDUCT OF BUSINESS.....	24
4.11 LABOR MATTERS	25
4.12 EMPLOYEE BENEFIT PLANS.....	26
4.13 ENVIRONMENTAL.....	28
4.14 CONTRACTS	29
4.15 PERMITS.....	30
4.16 INTELLECTUAL PROPERTY	31
4.17 FINANCIAL STATEMENTS	33
4.18 UNDISCLOSED LIABILITIES.....	33
4.19 ACCOUNTS RECEIVABLE.....	33
4.20 INVENTORIES	34
4.21 TAXES.....	34
4.22 CUSTOMERS; VENDORS.....	35
4.23 RELATED PARTY TRANSACTIONS.....	35
4.24 BOOKS AND RECORDS.....	35
4.25 PRODUCT LIABILITY AND WARRANTY	36
4.26 INSURANCE	36
4.27 BROKERS	36
4.28 GOVERNMENT CONTRACTS.....	36
4.29 NETWORK	37
4.30 REGULATORY MATTERS	38
4.31 CERTAIN BUSINESS PRACTICES.....	39
4.32 DISCLOSURE	40

Table of Contents

ARTICLE 5: REPRESENTATIONS AND WARRANTIES OF THE PURCHASER	40
5.1 EXISTENCE AND GOOD STANDING	40
5.2 POWER	40
5.3 ENFORCEABILITY	40
5.4 NO CONFLICT	40
5.5 CONSENTS	40
5.6 NO FINANCING CONTINGENCY	40
5.7 BROKERS	40
ARTICLE 6: COVENANTS.....	41
6.1 CONDUCT OF BUSINESS	41
6.2 ACCESS TO INFORMATION.....	42
6.3 FULFILLMENT OF CONDITIONS.....	43
6.4 INTERIM FINANCIAL STATEMENTS.....	43
6.5 NOTIFICATION TO CHANGES	43
6.6 EVIDENCE OF LIEN TERMINATIONS.....	43
6.7 CONSENTS	43
6.8 REGULATORY CONSENT	44
6.9 FURTHER ASSURANCES	45
6.10 SUPPLEMENTS TO DISCLOSURE SCHEDULES	45
6.11 EMPLOYEE MATTERS.....	45
6.12 TAX MATTERS	47
6.13 RISK OF LOSS.....	48
6.14 FINANCING COOPERATION	48
6.15 MEAG OFFICE LEASE AND MEAG RIGHTS AND ASSETS	49
6.16 UNIVERSAL SERVICE FUND CERTIFICATIONS.....	50
ARTICLE 7: CONDITIONS TO CLOSING	50
7.1 OF THE PURCHASER.....	50
7.2 OF THE SELLER.....	52
7.3 OF THE PARTIES.....	52
ARTICLE 8: CLOSING	53
ARTICLE 9: TERMINATION	53
9.1 TERMINATION.....	53
9.2 EFFECT OF TERMINATION	54
ARTICLE 10: REMEDIES	54
10.1 GENERAL INDEMNIFICATION OBLIGATION.....	54
10.2 NOTICE AND OPPORTUNITY TO DEFEND	55
10.3 SURVIVABILITY; LIMITATIONS.....	56
10.4 SPECIFIC PERFORMANCE.....	56
10.5 ADJUSTMENTS TO PURCHASE PRICE	57
10.6 RELEASE OF INDEMNIFICATION ESCROW AMOUNT.....	57
10.7 EXCLUSIVE REMEDY.....	57
ARTICLE 11: MISCELLANEOUS	58
11.1 PRESS RELEASE AND ANNOUNCEMENTS.....	58
11.2 NO ASSIGNMENT.....	58
11.3 HEADINGS.....	58

Table of Contents

11.4	INTEGRATION, MODIFICATION AND WAIVER	58
11.5	CONSTRUCTION.....	58
11.6	SEVERABILITY	58
11.7	NOTICES.....	58
11.8	GOVERNING LAW.....	60
11.9	COUNTERPARTS	60
11.10	JURISDICTION.....	60
11.11	EXPENSES	60
11.12	WAIVER OF JURY TRIAL.....	60
11.13	RISK OF LOSS.....	60

ASSET PURCHASE AGREEMENT

This Asset Purchase Agreement (this “**Agreement**”), dated as of _____, 202__, is by and between [Macquarie Newco, LLC], a Delaware limited liability company (the “**Purchaser**”) and Georgia Public Web, Inc., a Georgia non-profit corporation (the “**Seller**”).

Background

A. The Seller is engaged in the business of providing telecommunication services (the “**Business**”).

B. The Purchaser desires to purchase from the Seller, and the Seller desires to sell to the Purchaser, all of the Seller’s right, title and interest in and to the Purchased Assets (as hereinafter defined).

C. The Seller desires to transfer to the Purchaser, and the Purchaser desires to accept and assume from the Seller, the Assumed Liabilities (as hereinafter defined).

Now, therefore, in consideration of the mutual promises and representations and subject to the terms and conditions herein contained, and other good and valuable consideration, had and received, the receipt and sufficiency of which are hereby acknowledged, the parties hereto agree as follows:

ARTICLE 1: Definitions

“**Additional Inventory Item**” has the meaning set forth in Section 3.4(c).

“**Affiliate**” of any Person means any Person directly or indirectly controlling, controlled by, or under common control with, any such Person and any officer, director, or controlling person of such Person.

“**Agreement**” has the meaning set forth in the preamble.

“**Allocation**” has the meaning set forth in Section 3.3.

“**Allocation Schedule**” has the meaning set forth in Section 3.3.

“**Ancillary Agreements**” means the Bill of Sale, the Escrow Agreement, the Assumption Agreement, Assignment and Assumption of Lease and each agreement, document, instrument or certificate contemplated by this Agreement or to be executed by the Purchaser or the Seller in connection with the consummation of the transactions contemplated by this Agreement, in each case only as applicable to the relevant party or parties to such Ancillary Agreement, as indicated by the context in which such term is used.

“**Arbitration Firm**” has the meaning set forth in Section 3.2(c).

“**Assignment and Assumption of Lease**” has the meaning set forth in Section 7.1(h)(vii).

“**Assumed Liabilities**” has the meaning set forth in Section 2.4.

“**Assumption Agreement**” has the meaning set forth in Section 7.2(e)(ii).

“**Bill of Sale**” has the meaning set forth in Section 7.1(h)(ii).

“**Business**” has the meaning set forth in the recitals.

“**CARES Act**” means the Coronavirus Aid, Relief, and Economic Security Act of 2020, as in effect from time to time, together with all rules and regulations and guidance issued by any Governmental Authority with respect thereto and any similar or successor statute with respect thereto (including for the avoidance of doubt the Consolidated Appropriations Act of 2021, P.L. 116-260), and any similar applicable executive order or executive memo (including the Memorandum on Deferring Payroll Tax Obligations in Light of the Ongoing COVID-19 Disaster, dated August 8, 2020, and Internal Revenue Service Notice 2020-65).

“**Claims Notice**” has the meaning set forth in Section 10.2(a).

“**Closing**” has the meaning set forth in ARTICLE 8:

“**Closing Date**” has the meaning set forth in ARTICLE 8:

“**Closing Working Capital**” has the meaning set forth in Section 3.2(b).

“**Code**” means the Internal Revenue Code of 1986, as amended.

“**Communications Act**” means the Communications Act of 1934, as amended, and the rules, regulations, and published policies, procedures, orders and decision of the FCC.

“**Communications Law**” means (a) the Communications Act; (b) the State Telecommunications Laws; and (c) any Laws of any other Governmental Authority regulating or overseeing communications facilities or communications services, including Laws relating to the occupancy or use of any public rights-of-way.

“**Communications License**” means any Permit issued by the FCC, a State PUC or any applicable Governmental Authority pursuant to the applicable Communications Laws.

“**Consent Condition**” has the meaning set forth in Section 6.8(b).

“**Consents**” has the meaning set forth in Section 4.5.

“**Contracts**” means any contracts, agreements, purchase orders, bids, proposals, leases, instruments and other arrangements (whether written or oral) currently in effect.

“**Count**” has the meaning set forth in Section 3.4(b).

“**Debt Financing**” has the meaning set forth in Section 6.14(a).

“**Effective Time**” has the meaning set forth in ARTICLE 8:

“**Employee Benefit Plans**” has the meaning set forth in Section 4.12(a).

“**Environment**” means soil, soil gas, surface waters, groundwater, drinking water, natural resources (including flora and fauna), land, stream sediments, surface or subsurface strata, ambient air, indoor air or indoor air quality, including any material or substance used in the physical structure of any building or improvement.

“**Environmental Condition**” means any condition, existing on or before the Closing (but regardless of when discovered), of the Environment with respect to the Leased Real Property, which violates any Environmental Law, or results in any Release, or Threat of Release, claim, demand, order or liability.

1 1

“**Environmental Law**” means any Law relating to (a) protection of the Environment, (b) Releases, manufacture, generation, treatment, storage, sale, distribution, marketing, importation, exportation, labeling, processing, handling, recycling, reporting, registration or use of Hazardous Materials, or products containing Hazardous Materials, or (c) injury or adverse health effects to persons relating to exposure to any Hazardous Materials.

“**ERISA**” means the Employee Retirement Income Security Act of 1974, as amended.

“**ERISA Affiliate**” means any Person or entity that together with the Seller would be deemed to be under common control within the meaning of Section 414(b), (c), (m) or (o) of the Code or Section 4001(b)(1) of ERISA.

“**Escrow Agent**” means Citibank, N.A.

“**Escrow Agreement**” means that certain escrow agreement, to be executed on or prior to the Closing, by and among the Purchaser, the Seller, and the Escrow Agent, in the form of Exhibit A attached hereto.

“**Escrow Amount**” means the Indemnification Escrow Amount and the Working Capital Escrow Amount.

“**Escrow Release Date**” has the meaning set forth in Section 10.6(b).

“**Estimated Working Capital**” has the meaning set forth in Section 3.1(d).

“**Excess Amount**” has the meaning set forth in Section 3.2(f).

“**Expiration Date**” has the meaning set forth in Section 10.3(a).

“**Export Approvals**” has the meaning set forth in Section 4.31(c)(i).

“**FCC**” means the Federal Communications Commission.

“**FCC Approvals**” means such consents from, or such registrations, declarations, notices or other filings made to or with the FCC.

“**Final Inventory Report**” has the meaning set forth in Section 3.4(d).

“**Financial Statements**” has the meaning set forth in Section 4.17(a).

“**Fund Administrator**” means the entity that administers a state or the federal Universal Service Fund, state or federal telecommunications relay service fund, the North America Number Plan, or number portability.

“**GAAP**” means United States generally accepted accounting principles, applied on a consistent basis.

“**General Enforceability Exceptions**” has the meaning set forth in Section 4.3.

“**Government Contracts**” has the meaning set forth in Section 4.28(a).

“Governmental Authority” means any government or political subdivision or regulatory body, whether federal, state or local, or any agency or instrumentality of any such government or political subdivision or regulatory authority, or any federal, state, or local court or arbitrator or, with respect to the Purchaser only, any self-regulatory authority.

“Governmental Regulatory Approvals” means such consents from, or such registrations, declarations, notices or other filings made to or with, any Governmental Authority other than the FCC or a State PUC as are required in order to effect the assignment of applicable Purchased Assets, or as are otherwise necessary to consummate the transactions contemplated by this Agreement.

“GPW Maintained Huts” has the meaning set forth in Section 4.13.

“Hazardous Material” means any pollutant, toxic substance, including asbestos and asbestos-containing materials, hazardous waste, hazardous material, hazardous substance, contaminant, petroleum and petroleum-containing materials, asbestos-containing material, radiation and radioactive materials, leaded paints, toxic mold and other harmful biological agents, medical waste, infectious waste, polychlorinated biphenyls, fungicides, pesticides, insecticides, bactericides and germicides and any other materials and substances in any form as defined in, the subject of, or that could give rise to liability under, any Environmental Law.

“In-Service Inventory” has the meaning set forth in Section 3.4(a).

“Indebtedness” means (a) any indebtedness for borrowed money, (b) any indebtedness evidenced by any note, bond, debenture or other debt security, (c) any indebtedness for the deferred purchase price of property or services with respect to which a Person is liable, contingently or otherwise, as obligor or otherwise, (d) any commitment by which a Person assures a creditor against loss (including contingent reimbursement Liability with respect to letters of credit), (e) any indebtedness guaranteed in any manner by a Person (including guarantees in the form of an agreement to repurchase or reimburse), (f) any Liabilities under leases that would be considered capitalized leases under GAAP, (g) any indebtedness secured by a Lien on a Person’s assets, (h) any amounts owed to any Person under any noncompetition, severance or similar arrangement, (i) any change-of-control or similar payment or increased cost that is triggered in whole or in part by the transactions contemplated by this Agreement, (j) any Liability of a Person under deferred compensation plans, phantom stock plans, severance or bonus plans, accrued employee awards or similar arrangements made payable in whole or in part as a result of the transactions contemplated herein, including the employer portion of any payroll Taxes payable with respect to such amounts, (k) any off-balance sheet financing of a Person (but excluding all leases recorded for accounting purposes by the applicable Person as operating leases), (l) any accrued and unpaid interest on, and any prepayment premiums, penalties or similar contractual charges in respect of, any of the foregoing obligations computed as though payment is being made in respect thereof on the Closing Date, (m) liabilities associated with repairs of MEAG optical power ground wire, (n) MEAG fiber lease liability (o) any accrued but unpaid property or similar Taxes imposed with respect to the Purchased Assets or the Business for periods (or portions thereof) ending on or before the Closing Date, and (p) any Seller Transaction Expenses.

“Indemnification Escrow Amount” means an amount equal to \$2,000,000.

“Indemnified Party” has the meaning set forth in Section 10.2(a).

“Indemnifying Party” has the meaning set forth in Section 10.2(a).

“Indemnity Resolution Date” has the meaning set forth in Section 10.6(a).

1 9

“**Information Services**” has the meaning provided in Section 3(24) of the Communications Act, 47 U.S.C. § 153.

“**Information Systems**” means all computer hardware, databases and data storage systems, computer, data, database and communications networks (other than the Internet), architecture interfaces and firewalls (whether for data, voice, video or other media access, transmission or reception) and other apparatus used to create, store, transmit, exchange or receive information in any form.

“**Initial Purchase Price**” has the meaning set forth in Section 3.1(a).

“**Intellectual Property**” means any and all of the following in any jurisdiction throughout the world, by whatever name or term known or designated, tangible or intangible, whether arising by operation of Law, contract, license or otherwise: (a) all inventions (whether patentable or unpatentable and whether or not reduced to practice) as well as all improvements thereto; (b) all patents, patent applications of any kind and patent rights; (c) all copyrights in both published and unpublished works and registrations and applications for registration of any of the foregoing; (d) all trade secrets and other confidential or proprietary information (including all, technical, business, customer-related, and supplier-related information, technologies, processes, formulae, formulations, blends, blueprints, algorithms, industrial models, architectures, layouts, look-and-feel, designs, specifications, and methodologies) and rights under applicable trade secret Law in the foregoing (collectively, “**Trade Secrets**”); (e) registered and unregistered trademarks, service marks, trade names, and Internet domain names, and other indicia of source, origin or quality, together with all goodwill associated with any of the foregoing, and registrations and applications for registration of any of the foregoing; and (f) any and all other intellectual property rights and/or proprietary rights recognized by Law.

“**Interim Financial Statements**” has the meaning set forth in Section 4.17(a).

“**International Trade Laws**” means any applicable (i) Sanctions; (ii) U.S. export control applicable Law including, without limitation, the International Traffic in Arms Regulations (22 CFR §§ 120-130, as amended), the Export Administration Regulations (15 CFR §§ 730-774, as amended) and any regulation, order, or directive promulgated, issued or enforced pursuant to such applicable Law; (iii) Applicable Laws pertaining to imports and customs, including those administered by the Bureau of Customs and Border Protection in the U.S. Department of Homeland Security (and any successor thereof) and any regulation, order, or directive promulgated, issued or enforced pursuant to such applicable Laws; (iv) the anti-boycott applicable Laws administered by the U.S. Department of Commerce and the U.S. Department of the Treasury and (v) export, import and customs Applicable Laws of other countries in which the Seller has conducted and/or currently conducts business.

“**Interstate Traffic**” includes (a) Internet traffic, (b) interstate switched access, and (c) data or switched voice traffic that originates and terminates in different states.

“**Inventory Item**” has the meaning set forth in Section 3.4(a).

“**IRS**” means the U.S. Internal Revenue Service.

“**IRU**” has the meaning set forth in the definition of “Network Agreements.”

“**Knowledge of the Seller**” means the (i) actual, personal knowledge of Eric Snell, Kerry Hull, Shari Esposito and Greg Clay and (ii) the knowledge that would have been obtained after due inquiry and reasonable investigation by such Persons.

“**Law**” means any law, statute, code, ordinance, rule, regulation, common law or other requirement of any Governmental Authority.

“**Leased Real Property**” has the meaning set forth in Section 4.6(b).

“**Liability**” means any liability, debt, obligation, deficiency, Tax, penalty, assessment, fine, claim, cause of action or other Loss, fee, cost or expense of any kind or nature whatsoever, whether asserted or unasserted, absolute or contingent, known or unknown, accrued or unaccrued, liquidated or unliquidated, and whether due or to become due and regardless of when asserted.

“**Liability Claim**” has the meaning set forth in Section 10.2(a).

“**Licenses In**” has the meaning set forth in Section 4.16(f).

“**Licenses Out**” has the meaning set forth in Section 4.16(f).

“**Lien**” means any mortgage, pledge, hypothecation, deed of trust, lease, claim, security interest, encumbrance, easement, servitude, proxy, transfer restriction, option, lien, or charge.

“**Litigation Conditions**” has the meaning set forth in Section 10.2(b).

“**Location**” has the meaning set forth in Section 3.4(a).

“**Losses**” has the meaning set forth in Section 10.1(a).

“**Material Adverse Effect**” means any change or effect that is or would reasonably be expected to be, individually or in the aggregate, materially adverse on or to (a) the assets, the condition (financial or otherwise) or results of the operations of the Business as a whole, (b) the ability of the Seller to perform its obligations under this Agreement or to consummate the transactions contemplated by this Agreement, or (c) the validity, binding effect or enforceability of this Agreement, but does not include any such change or effect that is attributable to (i) any change (or changes taken together) or effect resulting from changes in general national or regional economic or financial conditions; (ii) any change (or changes taken together) or effect generally affecting national or regional telecommunications businesses; or (iii) any change in any Law applicable to any business in which such Person is engaged, other than to the extent that any such change (or changes taken together) or effect has a disproportionate impact on the Business as compared to other Persons operating in the same or substantially similar industries as the Business.

“**Material Contracts**” has the meaning set forth in Section 4.14(a).

“**Material Customers**” has the meaning set forth in Section 4.22(a).

“**Material Vendors**” has the meaning set forth in Section 4.22(b).

“**MEAG**” means the Municipal Electric Authority of Georgia.

“**MEAG Office Lease**” has the meaning set forth in Section 6.15.

“**MEAG Rights and Assets**” means all those rights and assets described in Schedule 4.7.

“**Members**” mean the members of the Seller.

“**Missing Item**” has the meaning set forth in Section 3.4(d).

“**Net Purchase Price**” has the meaning set forth in Section 3.1(a).

“**Net Working Capital**” means an amount equal to (a) the Seller’s current assets less (b) the Seller’s current liabilities, which assets and liabilities shall be determined in accordance with the principles set forth on Schedule 3.2(a).

“**Network**” has the meaning set forth in Section 4.29(a).

“**Network Agreements**” means each (a) indefeasible-right-of-use (“**IRU**”), fiber lease, license or similar right to use dark or lit network fiber or an associated wavelength to which the Seller is a recipient of the IRU, leased or licensed fiber or similar right; (b) underlying right, easement, right-of-way, license, pole attachment agreement, collocation or similar right or agreement in relation to network fiber owned by the Seller or permitting or requiring the laying, building operation or placement of cable, wires, conduits or other equipment or facilities over land, underground or in other third party locations for network fiber owned by the Seller (the rights described in clauses (a) and (b), the “**Network Underlying Rights**”); (c) other than Network Underlying Rights, each franchise agreement, license agreement or similar agreement or Law under which the Seller is authorized or permitted to place, keep or otherwise locate network fiber in or on public property owned or otherwise held by a municipality or similar Governmental Authority, but for clarity excluding business licenses and construction Permits; (d) other than Network Underlying Rights, each collocation agreement or similar agreement relating to locations where the Seller is authorized or permitted to place, keep or otherwise locate Network Facilities; (e) each interconnection agreement, peering agreement or similar agreement; (f) each agreement under which circuits, bandwidth, wavelength, capacity or Network Facilities used by the Seller to provide connectivity to, or at the request of, a customer is provided to or otherwise accessed by the Seller; (g) each agreement under which network fiber is serviced or maintained; (h) each agreement under which Network Equipment is serviced, maintained or purchased and (i) each amendment, modification or supplement to the agreements described in (a) through (h).

“**Network Equipment**” means all of the equipment used by the Seller to provide telecommunications services or information services (including voice over internet protocol and broadband internet access services) on or over the Network.

“**Network Facilities**” means the Network Equipment and the network fiber that comprise the Network, including fiber optic cabling and other fixed wired and wireless network-related assets and telecommunications equipment used by the Seller to carry out its business as presently conducted, whether owned, leased, or licensed by the Seller and irrespective of whether they are located on public or private property, including wires, cables, conduits, poles, antennas, microwave transmission equipment, junction boxes, manholes, hand holes, huts, connecting equipment and electronics.

“**Network Underlying Rights**” has the meaning set forth in the definition of “Network Agreements.”

“**No-Fault Change**” has the meaning set forth in Section 6.10.

“**Objection Notice**” has the meaning set forth in Section 3.2(c).

“**OFAC**” has the meaning set forth in the definition of “Sanctions.”

“**Order**” means any order, judgment, injunction, ruling, or writ of any Governmental Authority.

“Ordinary Course of Business” means the ordinary course of business consistent with past custom and practice of the Business and as customary for an intrastate middle mile telecommunications service provider.

“Other Representations” has the meaning set forth in Section 10.3(a).

“Owned Intellectual Property” means any and all Intellectual Property owned by the Seller or that the Seller claims it owns, whether in whole or in part.

“Permit” means any permit, license, approval, certificate, qualification, consent, or authorization issued by a Governmental Authority.

“Permitted Liens” has the meaning set forth in Section 4.6(a).

“Person” means any individual, sole proprietorship, partnership, corporation, limited liability company, unincorporated society or association, trust, or other entity.

“Personal Information” means information about an identified or identifiable individual.

“Preliminary Inventory List” has the meaning set forth in Section 3.4(a).

“Preliminary Inventory Report” has the meaning set forth in Section 3.4(c).

“Privacy Laws” means any Laws that govern the processing of Personal Information that are applicable to the Business.

“Proceeding” means any demand, charge, complaint, action, suit, proceeding, arbitration, hearing, investigation or claim of any kind (whether civil, criminal, administrative, investigative, informal or other, at law or in equity) commenced, filed, brought, or conducted by any Governmental Authority on or before the Closing Date.

“Purchase Price” has the meaning set forth in Section 3.1(c).

“Purchased Assets” has the meaning set forth in Section 2.1.

“Purchased Contracts” has the meaning set forth in Section 2.2(c).

“Purchaser” has the meaning set forth in the preamble.

“Purchaser Communications Licenses” has the meaning set forth in Section 6.8(a).

“Purchaser Indemnified Parties” has the meaning set forth in Section 10.1(a).

“Purchaser Plans” has the meaning set forth in Section 6.11(b).

“Real Property Leases” has the meaning set forth in Section 4.6(b).

“Registered Owned Intellectual Property” means all Owned Intellectual Property that is registered with, as applicable, the U.S. Patent and Trademark Office, the U.S. Copyright Office or any similar office or agency anywhere in the world.

“Regulatory Consent” means all authorizations, approvals, and consents from any Governmental Authority advisable or required by Law relating to any of the Purchased Assets for (a) the Seller to transfer and assign the Purchased Assets and the Business to the Purchaser, (b) the Purchaser to conduct the Business in accordance with Law and to own, lease, use, and operate the Purchased Assets at the places and in the manner in which the Business is conducted by the Seller as of the date of this Agreement and on the Closing Date, (c) the Purchaser to assume and perform the Purchased Contracts and Permits, (d) the FCC Approvals, (e) the State PUC Approvals, and (f) the Purchaser Communications Licenses.

“Regulatory Payments” means the amounts necessary to satisfy any billed or unbilled regulatory fees, assessments, fines, penalties, forfeitures, contributions or other payments assessed by or otherwise owed to the FCC, any State PUC, and the Fund Administrators or their agents, based upon the revenues of the Seller.

“Release” means any releasing, spilling, leaking, pumping, pouring, emitting, emptying, discharging, injecting, escaping, leaching, migrating, disposing, or dumping of a Hazardous Material into the Environment (including the abandonment or unpermitted discarding of barrels, containers and other closed receptacles containing any Hazardous Materials).

“Retained Assets” has the meaning set forth in Section 2.3.

“Retained Liabilities” has the meaning set forth in Section 2.5.

“Sanctions” means economic or financial sanctions, requirements or trade embargoes imposed, administered or enforced from time to time by U.S. Governmental Authorities (including the Office of Foreign Assets Control (“OFAC”), the U.S. Department of State and the U.S. Department of Commerce), the United Nations Security Council, the European Union, Her Majesty’s Treasury or any other relevant Governmental Authority.

“Sanctions Target” means any Person: (i) that is the subject or target of any Sanctions; (ii) named in any Sanctions-related list maintained by the U.S. Department of State; the U.S. Department of Commerce, including the Bureau of Industry and Security’s Entity List and Denied Persons List; or the U.S. Department of the Treasury, including the OFAC Specially Designated Nationals and Blocked Persons List, the Sectoral Sanctions Identifications List, and the Foreign Sanctions Evaders List; or any similar list maintained by the United Nations Security Council, the European Union, Her Majesty’s Treasury or any other relevant Governmental Authority; (iii) located, organized or resident in a country, territory or geographical region which is itself the subject or target of any territory-wide Sanctions (including the Crimea region of Ukraine, Cuba, Iran, North Korea, Syria and, prior to January 17, 2017, Sudan); or (iv) owned or controlled by any such Person or Persons described in the foregoing clauses (i)-(iii).

“Sandersville Hut” has the meaning set forth in Section 4.13.

“Schedules” means the disclosure schedules delivered by or on behalf of the Seller concurrently with the execution and delivery of this Agreement.

“Secure Networks Act” means the Secure and Trusted Communications Networks Act of 2019, Pub. L. No. 116-124, 133 Stat. 158 (2020) (codified as amended at 47 U.S.C. §§ 1601–1609).

“Seller” has the meaning set forth in the preamble.

“Seller 401(k) Plan” has the meaning set forth in Section 6.11(d).

“Seller Indemnity Payment” has the meaning set forth in Section 10.6(a).

“Seller Transaction Expenses” means any Liabilities incurred by the Seller (or by any other Person on behalf of the Seller) in connection with the negotiation of this Agreement, the Ancillary Agreements, the performance of such Person’s and its pre-Closing Affiliates’ obligations and covenants hereunder and thereunder, and the consummation of the transactions contemplated hereby and thereby.

“Shortfall Amount” has the meaning set forth in Section 3.2(e).

“Software” means all computer software and code, including assemblers, applets, compilers, source code, object code, development tools, design tools, user interfaces and data, in any form or format, however fixed, including databases and data collections.

“Spare Inventory” has the meaning set forth in Section 3.4(a).

“Special Representations” has the meaning set forth in Section 10.3(a).

“State PUC” means any state public service or public utilities commission, or similar state regulatory agency or body responsible for regulating the telecommunications industry within the states of Alabama, Florida, Georgia, or Tennessee or a particular state having regulatory authority over telecommunications services and/or any of the property, assets or business of the Seller.

“State PUC Approvals” means such consents from, or such registrations, declarations, notices or other filings made to or with, any State PUC as are required in order to effect the assignment of applicable Purchased Assets, or as are otherwise necessary to consummate the transactions contemplated by this Agreement.

“State Telecommunications Laws” means the state statutes governing intrastate telecommunications services and/or facilities and the rules, regulations, and published policies, procedures, orders and decisions of the State PUCs.

“Target Working Capital” means \$-1,238,268.

“Tax” means any United States federal, state or local net income, alternative minimum tax, gross income, gross receipts, gross margins, sales, use, ad valorem, business and occupation, unclaimed property or escheat, imputed underpayment, value added, transfer, franchise, profits, license, withholding, payroll, employment, unemployment, excise, stamp, occupation, property, motor vehicle registration, environmental or windfall profit tax, custom, duty or other tax, of any kind whatsoever, including any obligations to indemnify or otherwise assume or succeed to the Tax liability of any other person, together with any interest, penalty, or addition to tax imposed by any Law or Taxing Authority, whether disputed or not.

“Taxing Authority” means any Governmental Authority responsible for the imposition, determination, assessment, enforcement, correction, or administration of any Tax.

“Tax Returns” means all Tax returns, statements, reports, elections, schedules, claims for refund, and forms (including estimated Tax or information returns and reports), including any supplement or attachment thereto and any amendment thereof.

“Telecommunications” has the meaning provided in Section 3(50) of the Communications Act, 47 U.S.C. § 153.

“Telecommunications Service” has the meaning provided in Section 3(53) of the Communications Act, 47 U.S.C. § 153.

“Termination Date” has the meaning set forth in Section 9.1(c).

“Threat of Release” means a substantial likelihood of a Release that requires action to prevent or mitigate damage or harm to human health or the Environment that might result from such Release.

“Trade Secrets” has the meaning set forth in the definition of “Intellectual Property.”

“Transfer Taxes” has the meaning set forth in Section 6.12(b).

“Transferred Employee” and **“Transferred Employees”** have the meanings set forth in Section 6.11(a).

“Universal Service Fund” means a state or the federal mechanism designated by applicable Law to support the availability of communications services, whether in high cost areas or to specific classes of customers (such as schools and libraries, low income consumers, hospitals or other designated customer classes).

“Universal Service Subsidies” means any amounts paid from Universal Service Funds to carriers for services that qualify for support under a state or the federal Universal Service Fund.

“Unresolved Claim” has the meaning set forth in Section 10.6(b).

“USF Jurisdictional Certification” means a certificate from a customer stating whether or not a telecommunications circuit transmits or otherwise carries more than ten percent (10%) Interstate Traffic.

“USF Reseller Certificate” means a certificate from a reseller or wholesale customer that purchases telecommunications with respect to that customer’s Universal Service Fund contributions consistent with the requirements of the applicable FCC Form 499A Instructions.

“WARN Act” has the meaning set forth in Section 2.5(e).

“Working Capital Escrow Amount” means an amount equal to \$500,000.

“Working Capital Overage” has the meaning set forth in Section 3.1(d).

“Working Capital Statement” has the meaning set forth in Section 3.2(b).

“Working Capital Underage” has the meaning set forth in Section 3.1(d).

ARTICLE 2: Purchase and Sale of Assets

2.1 Agreement to Purchase and Sell; Assumption. Subject to the terms and conditions of this Agreement, at the Closing, and except as otherwise specifically provided in this Agreement, the Purchaser shall purchase from the Seller, and the Seller shall sell, transfer, assign, convey, and deliver to the Purchaser, all of the Seller’s right, title, and interest in and to all of its assets, rights, and properties of every nature, kind, and description, whether tangible or intangible, owned, leased, or licensed, real, personal, or mixed, but not including the Retained Assets (collectively, the **“Purchased Assets”**), free and clear of all Liens other than Permitted Liens, and the Purchaser shall assume the Assumed Liabilities.

2.2 **Purchased Assets.** Except as expressly set forth in Section 2.3 (with respect to Retained Assets), the Purchased Assets shall include the following assets, rights, and properties of the Seller as of the Closing Date:

- (a) all tangible property, including such property listed on Schedule 2.2(a);
- (b) all raw materials, supplies, work in process, finished goods, and other inventories, including such inventories listed on Schedule 2.2(b);
- (c) (i) the Contracts set forth on Schedule 2.2(c) and (ii) open sales orders or other Contracts for the sale of products or services with respect to which such products or services have not been delivered as of the Closing, whether or not set forth on Schedule 2.2(c) (collectively, the “**Purchased Contracts**”);
- (d) all Contracts (i) to which the Seller is a party prior to the Closing Date (ii) but that are not included on Schedule 2.2(c), and (iii) the benefits of which the Purchaser affirmatively accepts after the Closing Date by either (x) discharging the Seller’s obligations thereunder arising after the Closing Date or (y) receiving the Seller’s benefits thereunder arising after the Closing Date, as if it was the Seller. The Contracts described in this Section 2.2(d) shall be deemed Purchased Contracts as of the earliest date that the Purchaser discharges the obligations referred to in clause (x) of this Section 2.2(d) or receives the benefits referred to in clause (y) of this Section 2.2(d);
- (e) other than with respect to Tax refunds or Tax credits, all credits, rebates, prepaid expenses, advance payments, deposits, surety accounts and other similar deposits, including deposits with vendors;
- (f) all accounts and notes receivable, unbilled revenues, reimbursable costs and expenses and other claims for money due to the Seller, including the accounts receivable listed on Schedule 2.2(f);
- (g) all Owned Intellectual Property, including those items listed on Schedule 4.16(a), and all goodwill associated therewith and the right to sue and collect damages for past and future infringement, misappropriation, or violation of any rights in the Owned Intellectual Property;
- (h) all Network Equipment and all other machinery, materials, equipment, rolling stock, tools, and other tangible personal property owned or leased by the Seller and related to, used, or held for use in connection with the Business, the Network or any other Purchased Asset, including as identified on Schedule 2.2(h);
- (i) the Network and the Network Underlying Rights;
- (j) all Leased Real Property (and the Contracts related thereto) and any and all post office boxes used in the Business;
- (k) all Permits and building, safety, fire and health approvals, or any waiver of any of the foregoing, in each case, to the extent assignable;
- (l) the Business as a going concern and all of the goodwill associated with the Business, including all customer and vendor relationships;

(m) all telephone numbers, facsimile numbers, and email addresses owned by the Seller and used in the Business;

(n) except for the company minute books and related equity records of the Seller, all business records of the Seller and all employment records, to the extent permitted by law, with respect to the Transferred Employees, including all books, records, ledgers, files, documents, correspondence, lists (including customer and vendor lists and customer and vendor information, in whatever form or medium), plats, drawings, photographs, creative materials, advertising and promotional materials, studies, reports and other materials (in whatever form or medium), owned or maintained by the Seller;

(o) the Communications Licenses listed on Schedule 2.2(o);

(p) the USF Reseller Certificates and USF Jurisdictional Certifications obtained by the Seller from any customer; and

(q) all claims and causes of action of the Seller against third parties and all rights to proceeds therefrom.

2.3 Retained Assets. Notwithstanding anything in this Agreement to the contrary, the Seller shall retain those assets, rights, and properties set forth below (collectively, the “*Retained Assets*”):

(a) all cash, bank account balances, and cash equivalents owned by the Seller;

(b) the company minute books, communications with Members, and equity records of the Seller;

(c) all insurance policies owned or maintained by the Seller;

(d) all Employee Benefit Plans (including any Contracts related thereto) and all assets held with respect to the Employee Benefit Plans;

(e) all abandoned or unclaimed property under any applicable state or local unclaimed property, escheat, or similar Law;

(f) all rights that accrue to the Seller under this Agreement or any Ancillary Agreement;

(g) all prepaid premiums under insurance policies maintained by the Seller;

(h) any Permit or similar right that is not transferrable to the Purchaser;

(i) all Tax refunds, Tax credits, Tax deposits and advance Tax payments, and other Tax attributes that relate to the Purchased Assets or the Business, in each case for any Tax period (or portion thereof) that ends on or prior to the Closing Date, and all Tax papers, Tax Returns, worksheets, audit work papers, and similar documents of Seller and related to the Purchased Assets or the Business;

(j) all Contracts other than the Purchased Contracts;

- (k) any advance payments for IRUs received prior to the Closing Date associated with the Seller's Contracts with the Board of Regents of the University System of Georgia and Tower Cloud (who may now be doing business as Uniti) for periods after the Closing;
- (l) the MEAG Rights and Assets;
- (m) any Communications License not listed on Schedule 2.2(o) or not transferrable to the Purchaser; and
- (n) all assets set forth on Schedule 2.3(n).

The Purchaser will in no way be construed to have purchased or acquired (or to be obligated to purchase or to acquire) any interest whatsoever in any of the Retained Assets.

2.4 Assumed Liabilities. Effective as of the Closing Date, the Purchaser shall assume the following liabilities and obligations arising out of the conduct of the Business on or after the Closing Date (collectively, the "**Assumed Liabilities**"):

- (a) all trade accounts payable and accrued liabilities reflected on the Working Capital Statement (as finally determined pursuant to Section 3.2(c));
- (b) all liabilities and obligations of the Seller arising under or related to the Purchased Assets and Purchased Contracts, whether or not they are trade accounts payable or accrued liabilities reflected on the Working Capital Statement; provided, however, that the Purchaser will not assume or be responsible for any such liabilities or obligations (i) that arise from breaches of such Contracts or defaults under such Contracts on or prior to the Closing Date or (ii) relating to, based upon, or arising out of the packaging, sale, distribution, delivery, ownership, possession or use of products that were packaged, sold, delivered, or otherwise distributed, or services provided or delivered, by the Seller prior to the Closing Date, all of which liabilities and obligations listed in the foregoing Sections 2.4(b)(i) through (ii) constitute Retained Liabilities; and
- (c) all liabilities and obligations of the Seller arising under or related to any Contracts (i) to which the Seller is a party prior to the Closing Date (ii) but that are not included in Schedule 2.2(c), and (iii) the benefits of which the Purchaser affirmatively accepts after the Closing Date by either (x) discharging the Seller's obligations thereunder arising after the Closing Date or (y) receiving the Seller's benefits thereunder arising after the Closing Date, as if it was the Seller. The Contracts described in this Section 2.4(c) shall be deemed Purchased Contracts as of the earliest date that the Purchaser discharges the obligations referred to in clause (x) of this Section 2.4(c) or receives the benefits referred to in clause (y) of this Section 2.4(c).

2.5 Retained Liabilities. Other than the Assumed Liabilities, the Purchaser will not assume any liability or obligation of the Seller; whether in connection with the Purchased Assets, the Business or otherwise, of whatever nature, whether known or unknown, contingent or otherwise, and whether currently in existence or arising hereafter (collectively, "**Retained Liabilities**"). Without limiting the foregoing, the Retained Liabilities shall include:

- (a) all obligations and liabilities of the Seller not arising out of the operation of the Business or the ownership of the Purchased Assets;
- (b) all obligations and liabilities of the Seller related to, based upon, or arising out of any of the Retained Assets;

(c) all liabilities for (i) Taxes of the Seller or any Affiliate of the Seller (or for which the Seller is liable) for any taxable period; (ii) Taxes relating to the Retained Assets for any taxable period; (iii) Taxes relating to the Purchased Assets and Assumed Liabilities for any taxable period ending on or before the Closing Date and the portion through the Closing Date of any taxable period that includes but does not end on the Closing Date; and (iv) Transfer Taxes for which the Seller is liable under Section 6.12(b)6.12;

(d) all obligations and liabilities of the Seller with respect to any current or former employees, consultants, or independent contractors of the Seller, including liabilities or obligations (i) relating to the employment of, termination of, or provision of compensation, severance or benefits to such Persons; (ii) under any employment, wage and hour, equal opportunity, discrimination, plant closing or immigration and naturalization Laws; (iii) under any collective bargaining or labor Laws, agreements or arrangements; (iv) in connection with any workers' compensation or any other employee health, accident, disability (including any short-term disability salary continuation payment obligations, or long-term disability payment obligations for any employee who is receiving long-term disability payments from the Seller at the time of the Closing Date) or safety claims; and/or (v) triggered in connection with the consummation of the transactions contemplated hereby;

(e) all Liabilities of the Seller pursuant to the Worker Adjustment and Retraining Notification Act (the "*WARN Act*") or any similar state or local Laws arising on or prior to the Closing Date;

(f) all obligations and liabilities of the Seller with respect to (i) the Employee Benefit Plans and (ii) the matters specifically referenced in the last sentence of Section 6.11(a);

(g) all obligations and liabilities of the Seller relating to, based upon, or arising out of or under any Environmental Condition or Environmental Laws;

(h) all obligations and liabilities of the Seller related to, based upon, or arising out of the manufacture, packaging, sale, delivery, distribution, ownership, possession, or use of products that were manufactured, packaged, sold, distributed, or delivered, or services provided or delivered, by the Seller prior to the Closing Date, including (i) all obligations and liabilities related to, based upon, or arising out of the failure of any such products or services to conform to all applicable contractual commitments and (ii) all obligations and liabilities related to, based upon, or arising out of any injury to Person or property as a result of the ownership, possession, or use of such products or services, as applicable;

(i) all obligations and liabilities of the Seller related to, based upon, or arising out of any Proceeding against the Seller or related to the Business (whether currently pending) but excluding any relating to ownership of the Purchased Assets or operation of the Business after the Closing Date;

(j) all liabilities of the Seller for Regulatory Payments, including those that are invoiced after the Closing Date, for services provided by the Seller prior to the Closing Date;

(k) all liabilities of the Seller for Regulatory Payments resulting from the recharacterization by a company, a Fund Administrator or the FCC or State PUC of revenues for telecommunications (as defined in the Communications Act) provided by the Seller prior to the Closing Date;

(l) any and all liabilities of the Seller for the recovery by a Fund Administrator for Universal Service Subsidies received for services provided by the Seller prior to the Closing Date; and

(m) except for the Assumed Liabilities, all obligations and liabilities of the Seller related to, based upon, or arising out of the ownership and operation of the Business prior to the Closing (whether accrued, absolute, contingent, unasserted, or otherwise) including any Indebtedness of the Seller.

The Retained Liabilities will be retained by and remain the obligations of the Seller.

2.6 Transfer of Purchased Assets or Assumption of Assumed Liabilities not Effected at the Closing.

(a) If and to the extent that the valid, complete and perfected transfer or assignment to the Purchaser of any Purchased Assets or the assumption by the Purchaser of any Assumed Liabilities would be a violation of applicable Law or require any Consent or Regulatory Consent that has not been obtained at or prior to the Closing Date, then, unless the parties hereto shall mutually otherwise determine, the transfer or assignment to the Purchaser of such Purchased Assets or the assumption by the Purchaser of such Assumed Liabilities, as the case may be, shall be automatically deemed deferred and any such purported transfer, assignment or assumption shall be null and void until such time as all legal impediments are removed or such Consent or Regulatory Consent has been obtained. Notwithstanding the foregoing, any such Purchased Assets or Assumed Liabilities shall continue to constitute Purchased Assets and Assumed Liabilities for all other purposes of this Agreement.

(b) If any transfer or assignment of any Purchased Asset or any assumption of any Assumed Liability intended to be transferred, assigned or assumed under this Agreement is not consummated on or prior to the Closing Date, whether as a result of the provisions of Section 2.6(b) or for any other reason, then the parties hereto shall cooperate to effect such transfers as promptly following the Closing Date as practicable and, prior to the effectiveness of such transfer of Purchased Assets or assumption of Assumed Liabilities, the Seller shall thereafter hold such Purchased Asset in trust for the use and benefit of the Purchaser (at the expense of the Purchaser) and retain such Assumed Liability for the account of the Purchaser. In addition, the Seller shall, insofar as reasonably possible and to the extent permitted by applicable Law, treat such Purchased Asset or Assumed Liability in the Ordinary Course of Business and take such other actions as may be reasonably requested by the Purchaser in order to place the Purchaser in the same position as if such Purchased Asset or Assumed Liability had been transferred, assigned or assumed as contemplated hereby and so that all the benefits and burdens relating to such Purchased Asset or Assumed Liability, as the case may be, including use, risk of loss, potential for gain and dominion, control and command over such Purchased Asset or Assumed Liability, as the case may be, are to inure from and after the Closing Date to the Purchaser. Except to the extent otherwise required by applicable Law, each of the Seller and the Purchaser shall, and shall cause its Affiliates to, (i) for all Tax purposes, treat any Purchased Asset and any Assumed Liability transferred, assigned or assumed after the Closing Date pursuant to this Section 2.6(b) as having been so transferred, assigned or assumed on the Closing Date and (ii) file all Tax Returns in a manner consistent with such treatment and not take any Tax position inconsistent therewith. For the avoidance of doubt, to the extent the transfer or assignment of any Purchased Asset is not consummated on or prior to the Closing Date (other than a Purchased Asset for which the Seller elects to take a reduction to the Purchase Price pursuant to Section 3.4(e)(ii)), the transfer or assignment shall be effected pursuant to this Section 2.6(b) and Section 2.6(c) and the Purchase Price shall not be reduced.

(c) If and when the Consents or Regulatory Consents, the absence of which caused the deferral of transfer or assignment of any Purchased Asset or the deferral of assumption of any Assumed Liability pursuant to Section 2.6(b), are obtained or made, and, if and when any other legal impediments for the transfer or assignment of any Purchased Assets or the assumption of any Assumed Liabilities have been removed, the transfer or assignment of the applicable Purchased Asset or the assumption of the applicable Assumed Liability, as the case may be, shall be effected in accordance with the terms of this Agreement.

ARTICLE 3: Purchase Price; Adjustment; Allocation

3.1 Purchase Price.

(a) The aggregate purchase price paid by the Purchaser to the Seller in consideration for the Purchased Assets is an amount equal to \$40,000,000 minus (i) the Escrow Amount and (ii) the reduction of the Purchase Price provided in Section 3.4(e)(ii), if any (the result of the foregoing computation is referred to herein as the “**Initial Purchase Price**”) increased by (x) any Working Capital Overage or decreased by (y) any Working Capital Underage (as adjusted, the “**Net Purchase Price**”).

(b) At the Closing, the Purchaser shall disburse or cause to be disbursed (i) the Net Purchase Price to the Seller, by bank wire transfer of immediately available funds to an account designated in writing by the Seller and (ii) the Escrow Amount pursuant to the terms of and to the escrow account identified in the Escrow Agreement. (The Escrow Amount shall be disbursed pursuant to the terms of the Escrow Agreement.)

(c) The Assumed Liabilities, the Net Purchase Price, as finally adjusted in accordance with Section 3.2(e) or Section 3.2(f), as applicable, and that portion of the Escrow Amount that is actually released to the Seller, if any, are referred to herein as the “**Purchase Price**”.

(d) No less than three (3) business days prior to the Closing Date, Seller will prepare and deliver to the Purchaser a good faith estimate of the Net Working Capital as of the Effective Time (such estimate, the “**Estimated Working Capital**”). As contemplated by Section 3.1(a), if the Estimated Working Capital is less than the Target Working Capital, the Initial Purchase Price will be reduced by the amount of such shortfall (the “**Working Capital Underage**”), subject to further adjustment as provided in Section 3.2. If the Estimated Working Capital is greater than the Target Working Capital, the Initial Purchase Price will be increased by the amount of such excess (the “**Working Capital Overage**”), subject to further adjustment as provided in Section 3.2.

3.2 Purchase Price Adjustment.

(a) The Purchaser and the Seller agree that for purposes of determinations of Net Working Capital, including the calculation of Closing Working Capital, the principles set forth in on Schedule 3.2(a) shall be utilized.

(b) Within one-hundred twenty (120) days after the Closing Date, the Purchaser shall prepare and deliver to the Seller a working capital statement (the “**Working Capital Statement**”), setting forth the calculation of the Net Working Capital as of the Effective Time (the “**Closing Working Capital**”).

(c) Within thirty (30) days following delivery by the Purchaser of the Working Capital Statement, the Seller shall deliver written notice (the “**Objection Notice**”) to the Purchaser of any

dispute it has with respect to the preparation or content of such statement and the calculation of the Closing Working Capital. An Objection Notice must describe in reasonable detail the items contained in the Working Capital Statement that the Seller disputes and the basis for any such disputes. Any items not disputed in the Objection Notice will be deemed to have been accepted by the Seller. If the Seller does not deliver an Objection Notice with respect to the Working Capital Statement within such thirty (30)-day period, such statement will be final, conclusive, and binding on the parties. If the Seller delivers a timely Objection Notice, the Purchaser and the Seller shall negotiate in good faith to resolve such dispute. If the Purchaser and the Seller, notwithstanding such good faith effort, fail to resolve such dispute within thirty (30) days after the Seller delivers the Objection Notice, then the Purchaser and the Seller, jointly, shall engage a mutually acceptable nationally recognized independent accounting firm (the “*Arbitration Firm*”) to resolve such dispute. As promptly as practicable thereafter, the Purchaser and the Seller shall each prepare and submit a presentation to the Arbitration Firm. The scope of the disputes to be resolved by the Arbitration Firm is limited to the items in the Objection Notice that remain unresolved at the time the Arbitration Firm is engaged pursuant to this Section 3.2(c). As soon as practicable thereafter, the Purchaser and the Seller shall cause the Arbitration Firm to render a written decision resolving the matters submitted to the Arbitration Firm based solely upon the presentations by the Purchaser and the Seller. The Arbitration Firm may not assign a value greater than the greatest value for such item claimed by either party or smaller than the smallest value for such item claimed by either party. The fees and expenses of the Arbitration Firm incurred pursuant to this Section 3.2(c) shall be borne by the Seller, on the one hand, and the Purchaser, on the other hand, in proportion to the final allocation made by such Arbitration Firm of the disputed items weighted in relation to the respective amount of such claims made by the Seller, on the one hand, and the respective amount of such claim made by the Purchaser, on the other hand, such that the prevailing party pays the lesser proportion of such fees, costs and expenses. For example, if the Seller claims that the appropriate adjustments are \$1,000 greater than the amount claimed by the Purchaser and if the Arbitration Firm ultimately resolves the dispute by awarding to the Seller \$300 of the \$1,000 contested, then the fees, costs and expenses of the Arbitration Firm will be allocated 30% (i.e., $300 \div 1,000$) to the Purchaser and 70% (i.e., $700 \div 1,000$) to the Seller. All determinations made by the Arbitration Firm will be final, conclusive and binding on the parties hereto.

(d) For purposes of complying with the terms set forth in this Section 3.2, each party shall cooperate with and make available to the other party and its representatives all information, records, data, and working papers, and shall permit access to its facilities and personnel, as may be reasonably required in connection with the preparation and analysis of the Working Capital Statement and the resolution of any disputes thereunder; provided, however, that (i) the provision of any information or access pursuant to this Section 3.2(d) will be subject to appropriate confidentiality undertakings and, if applicable, execution of customary release letters in favor of the auditors as requested by the auditors in connection with the sharing of work papers and (ii) nothing in this Section 3.2(d) will require any party hereto to disclose information that is subject to attorney-client privilege.

(e) If the Closing Working Capital (as finally determined pursuant to Section 3.2(c)) is less than the Estimated Working Capital, then the Net Purchase Price will be adjusted downward by the amount of such shortfall (the “*Shortfall Amount*”) and the Seller and the Purchaser shall deliver a joint written instruction to the Escrow Agent not later than two (2) business days after the date upon which such determination shall have become final instructing the Escrow Agent to (A) release to the Purchaser from the account holding the Working Capital Escrow Amount an amount in cash equal to the Shortfall Amount and (B) release to the Seller the balance, if any, of the Working Capital Escrow Amount, in each case by wire transfer of immediately available funds, to an account designated in writing by the Purchaser or the Seller, as applicable. In the event the

Shortfall Amount exceeds the Working Capital Escrow Amount, then the Seller and the Purchaser shall deliver a joint written instruction to the Escrow Agent not later than two (2) business days after the date upon which such determination shall have become final instructing the Escrow Agent to release to the Purchaser from the account holding the Working Capital Escrow Amount the entirety of the Working Capital Escrow Amount and the Seller shall pay or cause to be paid to the Purchaser by wire transfer of immediately available funds, to an account or accounts designated in writing by the Purchaser, the amount by which the Shortfall Amount exceeds the Working Capital Escrow Amount.

(f) If the Closing Working Capital (as finally determined pursuant to Section 3.2(c)) is greater than or equal to the Estimated Working Capital, then the Net Purchase Price will be adjusted upward by the amount of any such excess (the “**Excess Amount**”) and (i) the Purchaser shall pay or cause to be paid to the Seller, not later than two (2) business days after the date upon which such determination shall have become final, an amount in cash equal to any Excess Amount by wire transfer of immediately available funds, to an account designated in writing by the Seller, and (ii) the Seller and the Purchaser shall deliver a joint written instruction to the Escrow Agent not later than two (2) business days after the date upon which such determination shall have become final instructing the Escrow Agent to release to the Seller from the account holding the Working Capital Escrow Amount an amount equal to the entire Working Capital Escrow Amount by wire transfer of immediately available funds, to an account designated in writing by the Seller.

(g) For the avoidance of doubt, any payments made pursuant to this Section 3.2 shall be treated as an adjustment to Net Purchase Price for all Tax purposes to the extent permitted by applicable Law.

3.3 Allocation.

(a) Within thirty (30) days after the finalization of the Purchase Price in accordance with Section 3.2, the Purchaser shall prepare and deliver to the Seller an allocation (the “**Allocation**”) of the Purchase Price (taking into account any adjustments thereto), the Assumed Liabilities and any other items treated as amounts realized for income Tax purposes among the Purchased Assets in accordance with Section 1060 of the Code, the Treasury Regulations thereunder, and the methodology as set forth on Schedule 3.3 (the “**Allocation Schedule**”). If the Seller disputes any portion of the Allocation Schedule, the dispute resolution provisions set forth in Sections 3.2(c) and 3.2(d) above shall apply *mutatis mutandis* to this Section 3.3.

(b) The Purchaser and the Seller shall report the purchase and sale of the Purchased Assets in accordance with the Allocation, as finalized pursuant to Section 3.3(a), on all relevant Tax Returns, including IRS Form 8594, including any amendments thereto. Except as otherwise required pursuant to any “determination” within the meaning of Section 1313(a) of the Code (or any comparable provision of state or local Law), neither the Purchaser nor the Seller (nor any relevant Affiliate of the Purchaser or the Seller) shall voluntarily take any position inconsistent with the Allocation, as finalized pursuant to Section 3.3(a). Within a reasonable period before the due date of all relevant Tax Returns, each of the Purchaser and the Seller shall reasonably cooperate with the other in preparing IRS Form 8594 or any equivalent statements required by any Taxing Authority, which shall be prepared consistently with the Allocation, as finalized pursuant to Section 3.3(a). The parties agree to notify each other with respect to the initiation of any Proceeding by any Taxing Authority relating to the Allocation as finally determined pursuant to Section 3.3(a) and agree to consult with each other with respect to any such Proceeding by any Taxing Authority.

3.4 Inventory.

(a) On or before the date hereof, the Seller shall prepare and deliver to the Purchaser an inventory substantially in the form of the following previously-provided files:

- (i) Schedule 2.2(a) – Tangible Property – In-Service Inventory – Draft v2.xlsx (the “***In-Service Inventory***”),
- (ii) Schedule 2.2(a) – Tangible Property – Spares Inventory – Draft v1.xlsx (the “***Spare Inventory***”),
- (iii) Schedule 2.2(a) – Tangible Property – Motor Vehicle Inventory – Draft v2.xlsx,
- (iv) Schedule 2.2(b) – Other Inventories – Spare Fiber Inventory – Draft v2.xlsx,
- (v) Schedule 2.2(b) – Other Inventories – Spare Outside Plant Inventory – Draft v2.xlsx, and
- (vi) Schedule 2.2(a) – Tangible Property – Tech Tool Inventory – Draft v1.xlsx

(such files collectively, the “***Preliminary Inventory List***”). The Preliminary Inventory List will not include the MEAG Huts and will not include any obsolete, to-be-replaced, or non-functioning items. The In-Service Inventory shall include equipment located in the MEAG Huts, even if that property is deemed to be owned by MEAG pursuant to the terms of the MEAG Master Agreement. The Preliminary Inventory List shall contain: (i) a description of each piece of inventory, (ii) the number of pieces of such inventory (each piece being an “***Inventory Item***”), and (iii) the Inventory Item’s stationary location as of the date of this Agreement (if the Inventory Item is stationary) or its overnight storage location as of the date of this Agreement (if the Inventory Item is a vehicle, trailer or carried on a vehicle or trailer) (whichever is applicable, the “***Location***”).

(b) Within ten (10) business days after the date of this Agreement, the Purchaser or its agent will commence a visual count of the Inventory Items (the “***Count***”). For clarification, the Count shall have no impact on the operation or functioning of the Network and will not include any plugging in or unplugging of Inventory Items. The Seller will designate an employee to escort and provide the Purchaser or its agent with access to all Inventory Item Locations. The Count shall take place on weekdays during normal business hours. Purchaser and its agent shall (and Purchaser shall cause the agent to) use reasonable best efforts to complete the Count within thirty (30) days, but not more than forty-five (45) days from commencement the Count.

(c) Within twenty (20) business days after the completion of the Count, the Purchaser shall submit a preliminary report to the Seller indicating the number and type of each Inventory Item that is

- (i) missing from its respective Location as indicated in the Preliminary Inventory List (except for vehicles, trailers or equipment carried on vehicles or trailers that are away from their Location in the Ordinary Course of the Business),
- (ii) In-Service Inventory having a value of \$2,500 or more as indicated on the Preliminary Inventory List but that is incapable of being operated,
- (iii) Spare Inventory having a value of \$2,500 or more as indicated on the Preliminary Inventory List but that is incapable of being operated, or
- (iv) in addition to the number and type of Inventory Items indicated in the Preliminary Inventory List for each particular Location (each, an “***Additional Inventory Item***”).

The report described in this Section 3.4(c) shall be the “*Preliminary Inventory Report*.”

(d) The parties shall have ten (10) business days after the Seller receives the Preliminary Inventory Report to reconcile any errors or oversights in the Preliminary Inventory Report and to come up with a final, complete and accurate list of each (i) Inventory Item described in Section 3.4(a) (i), (ii) and (iii) (each, a “*Missing Item*”) and (ii) Additional Inventory Item. The report described in this Section 3.4(d) shall be the “*Final Inventory Report*.”

(e) Within ten (10) business days of receiving the Final Inventory Report, the Seller shall have the option of either (i) replacing such Missing Item included on the Final Inventory Report, either by (A) substituting an Additional Inventory Item of the same type, (B) purchasing a replacement of such Missing Item (or submitting a purchase order to purchase a replacement of such Missing Item included on the Final Inventory Report that cannot be physically obtained by the Seller within ten business days) with the same, functionally-equivalent or better item, at the Seller’s sole cost or expense, or (C) for any Missing Item of the types included in Spare Inventory finding the same or similar item for such Missing Item and that is not included on the Spare Inventory or (ii) reducing the Purchase Price by the replacement cost (as reasonably determined by the Purchaser) of each Missing Item not replaced or purchased under Section 3.4(e)(i).

(f) For the avoidance of doubt, any reductions made pursuant to this Section 3.4 shall be treated as an adjustment to the Net Purchase Price for all Tax purposes.

ARTICLE 4: Representations and Warranties of the Seller

The Seller represents and warrants to the Purchaser as follows, both as of the date of this Agreement and on the Closing Date, except as otherwise specifically noted in any particular representations or warranties:

4.1 Existence; Good Standing and Capitalization. The Seller is a nonprofit corporation duly incorporated, validly existing and in good standing under the laws of the State of Georgia, and is duly qualified to do business as a foreign corporation and is in good standing in the jurisdictions set forth on Schedule 4.1(a), which are the only jurisdictions in which the Seller is required to be so qualified. The Seller does not own any equity interests in any Person. The Seller has the Members set forth on Schedule 4.1(b). There are no options, warrants or other rights, agreements, arrangements or commitments of any character relating to the issued or unissued capital stock of, or other equity interests in, the Seller or obligating the Seller to issue or sell any shares of capital stock of, or other equity interests in, the Seller. The Seller has delivered to the Purchaser true, complete, and correct copies of the articles of incorporation, as currently in effect and reflecting any and all amendments thereto through the Closing Date. Such organizational documents are in full force and effect.

4.2 Power. The Seller has the power and authority to (a) own, operate, and lease its properties and assets as and where currently owned, operated, and leased, and (b) carry on its business as currently conducted. The Seller has the requisite power and authority to execute, deliver, and perform its obligations under this Agreement and the Ancillary Agreements.

4.3 Enforceability. The execution, delivery, and performance of this Agreement and the Ancillary Agreements, and the consummation of the transactions contemplated hereby and thereby, have been duly and validly authorized by all necessary action on the part of the Seller and the Members. This Agreement and each of the Ancillary Agreements have been duly executed and delivered by the Seller, and constitute the valid and legally binding obligations of the Seller, enforceable against the Seller in

accordance with their terms, subject to applicable bankruptcy, insolvency, reorganization, moratorium, liquidation, fraudulent conveyance, and other similar Laws and principles of equity affecting creditors' rights and remedies generally (the "**General Enforceability Exceptions**").

4.4 **No Conflict.** Except as set forth on Schedule 4.4, neither the execution of this Agreement nor the Ancillary Agreements, nor the performance by the Seller of its obligations hereunder, nor the consummation of the transactions contemplated hereby will (a) assuming all Regulatory Consents have been obtained or made, violate any Law or Order applicable to the Seller, (b) violate or conflict with the Seller's organizational documents, (c) violate, conflict with, or result in a breach or termination of, or otherwise give any Person additional rights or compensation under, or the right to terminate or accelerate, or the loss of a material benefit under, or constitute (with notice or lapse of time, or both) a default under the terms of any Purchased Contract to which the Seller is a party or by which any of the Purchased Assets are bound or (d) result in the creation or imposition of any Lien with respect to, or otherwise have an adverse effect upon, any of the Purchased Assets.

4.5 **Consents.** Except as set forth on Schedule 4.5, no (a) consent, approval, authorization of, or notice to any third party ("**Consents**") or (b) Regulatory Consent is required in connection with the execution and delivery by the Seller of this Agreement or the Ancillary Agreements or the consummation of the transactions contemplated hereby or thereby.

4.6 **Property.**

(a) **Title.** The Seller has good and marketable title to, or valid and enforceable leasehold interests in, all of the Purchased Assets, in each case free and clear of all Liens other than (i) Liens for current Taxes that are not due and payable as of the Closing Date or that are being contested in good faith by appropriate proceedings, and (ii) those matters described on Schedule 4.6(a) (collectively, the "**Permitted Liens**"). The Purchased Assets are in good condition and repair (subject to normal wear and tear). All of the Purchased Assets have been maintained, repaired, and replaced consistent with past practice. Except as described on Schedule 4.6(a), the Seller does not own, and has never owned, any real property.

(b) **Leased Real Property.** Schedule 4.6(b) sets forth (i) a true and complete description of all real property that is leased, subleased, licensed to, or otherwise used or occupied by the Seller and all real property interests of the Seller in third party property, including easements, rights of way or similar rights of access necessary for all lawful access to, use, maintenance, repair and operation of the Network (collectively, the "**Leased Real Property**"), including the address thereof, the annual fixed rental charges, the expiration of the term, any extension options and any security deposits, and (ii) a list of all leases, licenses, easements and similar agreements, including all amendments, extensions and renewals thereof and guarantees, and security agreements pertaining to the Leased Real Property (collectively, the "**Real Property Leases**"). The Seller has valid and enforceable leasehold interests or valid legal right or title in all of its Leased Real Property. All of the Leased Real Property is used or occupied by the Seller pursuant to a Purchased Contract. All Real Property Leases are valid and binding agreements of the Seller and the counterparties thereto, are in full force and effect (except for those that have terminated or will terminate by their own terms), and are enforceable against the Seller and, to the Knowledge of the Seller, all other counterparties thereto, subject to the General Enforceability Exceptions. Neither the Seller nor, to the Knowledge of the Seller, any other party thereto is in violation or breach of or in default (or with notice or lapse of time, or both, would be in violation or breach of or in default) under the terms of any Real Property Lease. The Seller has not received any written notice alleging violation, breach or default under any such Real Property Lease. Except as set forth on Schedule 4.6(b), the Seller has not leased or sublet as lessor or sublessor nor assigned, and no third

party is in possession of, any of the Leased Real Property

(c) Reassessment. There is not now pending or, to the Knowledge of the Seller, contemplated any reassessment of any parcel included in the Leased Real Property that could result in a material increase in the rent, additional rent or other sums and charges payable by the Seller under any agreement relating to the Leased Real Property.

(d) No Condemnation. There is not now pending or, to the Knowledge of the Seller, contemplated any condemnation, expropriation, eminent domain, or similar proceeding affecting all or any portion of the Leased Real Property. The Seller has not received any written notice or oral notice of any such proceeding, and to the Knowledge of the Seller, no such proceeding is contemplated.

(e) Operation of Property. There are no material defects in, mechanical failure of, or damage to, the Leased Real Property. The Leased Real Property is sufficient for the operation of the Business as it is currently conducted. The Seller has obtained all Permits necessary for the operation of the Business at the Leased Real Property and such Permits will be transferred and assigned to the Purchaser as of the Closing, to the extent they are assignable.

(f) Brokerage Commissions. The Seller does not owe any material brokerage commissions or finder's fees with respect to any Real Property Lease or any renewal or extension thereof or the exercise of any right or option thereunder.

4.7 Necessary Property. Except for the MEAG Rights and Assets and other items set forth on Schedule 4.7, the Purchased Assets, when transferred to the Purchaser, will be adequate and sufficient to permit the Purchaser to conduct the Business as conducted by the Seller immediately prior to the Closing Date. The Seller is the only entity through which the Business is conducted.

4.8 Proceedings. Except as set forth on Schedule 4.8, there is no instance in which the Seller is or has been, or the Purchased Assets are or have been, in each case within the three (3)-year period prior to the Closing Date (a) subject to any unsatisfied Order or (b) a party, or, to the Knowledge of the Seller, threatened to be made a party, to any Proceeding. There are no Proceedings pending or, to the Knowledge of the Seller, threatened that question the validity of this Agreement, the Ancillary Agreements or any of the transactions contemplated hereby or thereby. To the Knowledge of the Seller, no event has occurred or circumstances exist that could give rise to or serve as a basis for the commencement of any Proceeding by or against the Seller.

4.9 Compliance with Laws.

(a) The Seller is now, and has been, and the Purchased Assets are now and have been operated, in substantial compliance with all Laws and Orders. Except as set forth on Schedule 4.9(a), to the Knowledge of the Seller, there is no proposed Law or Order that would have a material adverse effect, when taken as a whole, on the Seller, the Purchased Assets, the Business or the liabilities, operations or prospects of the Business. The Seller has not received any notice from any Governmental Authority or any other Person regarding any actual, alleged or potential violation of, or failure to comply with, or liability under any applicable Law.

(b) During the last six (6) years: (i) all written representations, certifications, and disclosures made by or on behalf of the Seller relating to any Government Contract were current, accurate, and complete at the time of certification or disclosure and (ii) except as set forth on Schedule 4.9(a), neither any Governmental Authority nor any prime contractor, subcontractor, or

other Person has notified the Seller in writing or, to the Knowledge of the Seller, orally that the Seller has, or is alleged to have, breached or violated any Law, representation, certification, disclosure, clause, provision, or requirement pertaining to any Contract.

4.10 Conduct of Business. Except as set forth on Schedule 4.10, since December 31, 2020 the Seller has conducted its business in the Ordinary Course of Business and there has not been any material adverse change in the operation of its business or the performance, financial condition or prospects of the Seller. Without limiting the generality of the foregoing, since December 31, 2020, the Seller has not:

(a) borrowed any amount or incurred or become subject to any liability except (i) current liabilities incurred in the Ordinary Course of Business, (ii) liabilities under Contracts entered into in the Ordinary Course of Business, and (iii) borrowings under lines of credit existing on such date;

(b) mortgaged, pledged, or subjected to any Lien, any of the Purchased Assets, except Permitted Liens;

(c) sold, assigned, or transferred (including transfers to any employees) any Purchased Assets except in the Ordinary Course of Business, or canceled any debts or claims;

(d) waived any rights of material value;

(e) taken any other action or entered into any other transaction or Contract (including any transactions with employees) other than in the Ordinary Course of Business or other than the transactions contemplated by this Agreement;

(f) made any material change in accounting or Tax principles, practices, policies, or methods;

(g) with respect to the Purchased Assets or the Business, (i) amended any Tax Return, (ii) entered into any "closing agreement" as described in Section 7121 of the Code (or any similar provision of state, local or foreign Law) with any Tax authority with respect to a Tax, (iii) settled any claim or assessment in respect of any Tax, or (iv) consented to any extension or waiver of the limitation period applicable to any claim or assessment in respect of any Tax that would give rise to any claim or assessment of Taxes;

(h) made any write-off or write-down of or made any determination to write-off or write-down any of its assets and properties other than in the Ordinary Course of Business;

(i) made any change in its general pricing practices or policies or any change in the credit or allowance practices or policies;

(j) accelerated revenues, collected on accounts receivable or deferred expenses or the payment of accounts payable, in each case other than in the Ordinary Course of Business;

(k) engaged in any activity that reasonably could be expected to result in a reduction, temporary or otherwise, in the demands for products following the Closing;

(l) commenced or terminated any line of business;

(m) experienced any damage, destruction or casualty loss in excess of \$5,000 (other than those covered by insurance) with respect to any of the Purchased Assets;

(n) made any capital expenditures that aggregate in excess of \$500,000;

(o) instituted or settled any Proceeding for an amount involving in excess of \$100,000 in the aggregate or involving equitable or injunctive relief;

(p) as to any current or former employees or independent contractors of the Seller: (i) granted any bonuses, whether monetary or otherwise, or increased any wages, salary, severance, pension or other compensation or benefits, other than as provided for in any written agreements or required by applicable Law, (ii) changed the terms of employment, or (iii) accelerated the vesting or payment of any compensation or benefit;

(q) adopted, modified or terminated any (i) employment, severance, retention or other agreement with any current or former employee or independent contractor of the Seller; (ii) Employee Benefit Plan; or (iii) collective bargaining agreement, in each case whether written or oral;

(r) acquired any other business or Person (or any significant portion or division thereof), whether by merger, consolidation or reorganization or by purchase of its assets or equity interests, or acquired any other material assets; or

(s) committed or agreed, in writing or otherwise, to any of the foregoing, except as expressly contemplated by this Agreement and the Ancillary Agreements.

4.11 Labor Matters.

(a) Union and Employee Contracts. (i) The Seller is not a party to or bound by any union contract, collective bargaining agreement or other similar type of contract with any labor organization, (ii) the Seller has not agreed to recognize any union or other collective bargaining representative, (iii) no union or other collective bargaining representative has been certified as representing any employees of the Seller, (iv) there has not been any union organizing activity to the Knowledge of the Seller with respect to any employees of the Seller during the past five (5) years, (v) the Seller has not experienced any labor strike, slowdown, work stoppage, or any other labor dispute during the past five (5) years; and (vi) there are no unfair labor practice charges, grievances, or complaints pending, or to the Knowledge of the Seller, threatened by or on behalf of any employee or group of employees of the Seller. Except as disclosed on Schedule 4.11(a), the Seller is not bound by any independent contractor agreement or consultant agreement.

(b) List of Employees, Etc. Schedule 4.11(b) lists, to the extent applicable, for each employee, independent contractor, consultant, and sales representative of the Seller or any individual who provides services to the Seller, his or her: name, title, location, date of hire or engagement, exempt/non-exempt status, employment status (i.e., whether full-time, temporary, leased, etc.), active or inactive status (including type of leave, if any), accrued but unused vacation (as of the date indicated on Schedule 4.11(b)), current year annual base salary or hourly wage rate (or other compensation), current year target bonus/commission and current year to date total compensation (as of the date indicated on Schedule 4.11(b)). Except as set forth on Schedule 4.11(b), the employees of the Seller are “at will” and, to the Knowledge of the Seller, no employee of the Seller intends to terminate his or her employment or other relationship with the Seller.

(c) Unemployment, Social Security and Other Benefits. The Seller is not liable for any payment to any trust or other fund or to any Governmental Authority, with respect to unemployment compensation benefits, social security or other benefits or, except as disclosed in Schedule 4.11(c), obligations for employees (other than routine payments to be made in the Ordinary Course of Business). There are no pending claims against the Seller under any workers' compensation plan or policy or for long-term disability.

(d) Manuals, Handbooks, Policies, etc. True and complete copies have been made available to the Purchaser of the material written personnel manuals, handbooks, policies, rules or procedures applicable to any employee of the Seller.

(e) Compliance and Investigations. Neither the Seller, nor any of its officers, have received within the past five (5) years any written or, to the Knowledge of the Seller, oral notice of intent by any Governmental Authority responsible for the enforcement of labor or employment laws to conduct an investigation relating to the Seller and no such investigation is in progress. The Seller is not a party to, or otherwise bound by, any consent decree with, or citation by, any Governmental Authority relating to employees or employment practices. The Seller is in compliance with all applicable Laws respecting labor and employment, including termination of employment or failure to employ, employment practices, terms and conditions of employment, immigration, wages and hours, working time, employment standards, civil rights, discrimination and retaliation, occupational safety and health, family or medical leave, exempt/non-exempt and contingent worker classifications and workers' compensation. There are no labor or employment actions pending, or to the Knowledge of the Seller threatened, between the Seller and any employees, current or former, of the Seller.

(f) Foreign Employees. No employee of the Seller is under a work permit or visa. To the Knowledge of the Seller, all employees who are performing services for the Seller are legally permitted to work in the United States.

(g) WARN Act. In the five (5) years prior to the date of this Agreement, the Seller has not effectuated (i) a "plant closing" (as defined in the WARN Act or any similar state, local or foreign Law) affecting any site of employment or one or more facilities or operating units within any site of employment or facility related to the Business or (ii) a "mass layoff" (as defined in the WARN Act, or any similar state, local or foreign Law) affecting any site of employment or facility related to the Business.

(h) There are not now, and have not been in the past five years, any internal or external complaints of any type of harassment, including sexual harassment, made against any employee or, to the Knowledge of the Seller, any service provider of the Seller or by any employee or to the Knowledge of the Seller, any service provider of the Seller.

4.12 Employee Benefit Plans.

(a) Schedule 4.12(a) sets forth a correct and complete list of (i) all "employee benefit plans," as defined in Section 3(3) of ERISA, (ii) all other employment, severance pay, change in control, salary continuation, bonus, incentive, stock option, equity-based, retirement, pension, profit sharing or deferred compensation plans, contracts, programs, funds, or arrangements of any kind, and (iii) all other employee benefit plans, contracts, programs, funds, or arrangements (whether written or oral, qualified or nonqualified, funded or unfunded) and any trust, escrow, or similar agreement related thereto, whether or not funded, in respect of any present or former employees or officers of the Seller that are sponsored or maintained by the Seller or with respect to

which the Seller has made or is required to make payments, transfers, or contributions or with respect to which the Seller has or may have any liability or obligation, including by reason of being an ERISA Affiliate (all of the above being hereinafter individually or collectively referred to as “*Employee Benefit Plan*” or “*Employee Benefit Plans*,” respectively). The Seller does not have any liability with respect to any plan, arrangement, or practice of the type described in the preceding sentence other than the Employee Benefit Plans.

(b) Each Employee Benefit Plan has been maintained, operated, and administered in compliance with its terms and any related documents or agreements and in compliance with all applicable Laws. No suit, litigation, investigation, administrative proceeding, disputed claim, settlement, adjudication or action (other than routine claims for benefits) has been brought or is pending, or to the Knowledge of the Seller, is threatened, against or with respect to any such Employee Benefit Plan or the assets of any such plan. Any Employee Benefit Plan intended to be qualified under Section 401(a) of the Code has obtained from the IRS a favorable determination or opinion letter as to its qualified status under the Code and nothing has occurred since the issuance of each such letter that would reasonably be expected to cause the loss of the tax-qualified status of any Employee Benefit Plan subject to Section 401(a) of the Code.

(c) True, up-to-date, correct and complete copies of the following documents with respect to each of the Employee Benefit Plans have been made available to the Purchaser to the extent applicable: (i) summaries of the material terms of all Employee Benefit Plans; (ii) the most recent IRS determination or opinion letter; and (iii) all material communications regarding the Employee Benefit Plans sent by the Seller in 2021, 2020 and 2019 to employees of the Business.

(d) Neither the Seller nor any of its ERISA Affiliates currently has any, and at no time in the past has had any, obligation to contribute to or any liability under (i) a “defined benefit plan” as defined in Section 3(35) of ERISA, (ii) a pension plan subject to the funding standards of Section 302 of ERISA or Section 412 of the Code, (iii) a “multiemployer plan” as defined in Section 3(37) of ERISA or Section 414(f) of the Code or (iv) a “multiple employer plan” within the meaning of Section 210(a) of ERISA or Section 413(c) of the Code. The Seller has not incurred, and, to the Knowledge of the Seller, no event has occurred and no condition or circumstance exists that could result, directly or indirectly, in, any unsatisfied liability (including any indirect, contingent or secondary liability) of the Seller under Title IV of ERISA or Section 412 or 430 of the Code or Section 302 or 303 of ERISA. No asset or property of the Seller is or may be subject to any lien arising under Section 430(k) of the Code or Section 303(k) of ERISA.

(e) Full payment has been made of all amounts that the Seller is required under applicable Law or under any Employee Benefit Plan or any agreement relating to any Employee Benefit Plan to have paid as contributions or premiums thereunder.

(f) Except as set forth on Schedule 4.12(f), the execution and performance of this Agreement will not (i) constitute a stated triggering event under any Employee Benefit Plan that will result in any payment (whether of severance pay or otherwise) becoming due from the Seller to any current or former officer or employee (or dependents of such Persons) of the Seller, or (ii) accelerate the time of payment or vesting, or increase the amount of compensation due to any current or former officer, or employee (or dependents of such Persons) of the Seller.

(g) Except as disclosed in Schedule 4.12(g), no amount that could be received (whether in cash or property or the vesting of property) as a result of any of the transactions contemplated by this Agreement by any employee or officer of the Seller or any of its Affiliates who is a “disqualified individual” (as such term is defined in Treasury Regulation Section 1.280G-

1) could be characterized as an “excess parachute payment” (as such term is defined in Section 280G(b)(1) of the Code).

(h) Each Employee Benefit Plan that constitutes in any part a nonqualified deferred compensation plan within the meaning of Section 409A of the Code has been operated and maintained in all material respects in operational and documentary compliance with Section 409A of the Code and applicable guidance thereunder. No payment to be made under any Employee Benefit Plan is, or to the Knowledge of the Seller, will be, subject to the penalties of Section 409A(a)(1) of the Code.

(i) None of the Employee Benefit Plans, nor any liability of any kind thereunder or with respect thereto, will be required by operation of law or otherwise (except as expressly provided herein) to be transferred to the Purchaser and/or its Affiliates as a result of the transactions contemplated hereby.

4.13 Environmental. The representations in Sections 4.13(a), (b), (d), (e)(ii), (g), and (i) apply only to: (i) the 14 MEAG huts referenced in Schedule 2.2(a) and only for the period since the date of the MEAG Master Agreement and (ii) the Sandersville, Georgia hut referenced in the Leased Real Property and only for the period since September 2, 2008 (the “*Sandersville Hut*”) and only for the period since the date of the Real Property Lease for same as disclosed on Schedule 4.6(b) (such locations, including the contiguous real property immediately surrounding such huts (up to any fences surrounding the huts) and the contiguous real property immediately surrounding the above ground tanks that service such huts, being the “*GPW Maintained Huts*”). Except as set forth on Schedule 4.13:

(a) To the Knowledge of the Seller, there are no, and have not been any, underground tanks and related pipes, pumps, and other facilities for such underground tanks regardless of their use or purpose whether active or abandoned at the Leased Real Property.

(b) To the Knowledge of the Seller, there is no asbestos nor any asbestos containing materials used in, applied to, or in any way incorporated in any building, structure, or other form of improvement on the Leased Real Property.

(c) The Seller is presently and for the preceding five (5) years has been in material compliance with all Environmental Laws applicable to the Leased Real Property or its business.

(d) There exists no Environmental Condition that requires reporting, investigation, assessment, cleanup, remediation, or any other type of response action pursuant to any Environmental Law or that could be the basis for any material liability of any kind pursuant to any Environmental Law.

(e) (i) The Seller has not generated, manufactured, refined, transported, treated, stored, handled, disposed, transferred, produced, or processed any Hazardous Materials at or upon the Leased Real Property, except in material compliance with all applicable Environmental Laws, and (ii) to the Knowledge of the Seller, there has been no Release or Threat of Release of any Hazardous Material at the Leased Real Property that requires or may require reporting, investigation, assessment, cleanup, remediation or any other type of response action by the Seller pursuant to any Environmental Law.

(f) The Seller has not: (i) entered into or been subject to any consent decree, compliance order, or administrative order with respect to the Release of any Hazardous Materials or any Environmental Law; (ii) received any written request for information, notice, demand letter,

administrative inquiry, or written complaint or claim with respect to any Environmental Condition, Release of any Hazardous Materials or liability under any Environmental Law; or (iii) been subject to or threatened with any governmental or citizen enforcement action with respect to any Environmental Law.

(g) There currently are effective all Permits required under any Environmental Law that are necessary for the Seller's activities and operations or use of the Leased Real Property and the Seller has materially complied with the terms and conditions of such Permits since issuance.

(h) The Seller has not sold, marketed, or distributed any product that contains asbestos.

(i) The Seller has made available to the Purchaser copies of all material documents, records, and written information in its possession or control concerning Environmental Conditions and potential liability under Environmental Laws, including previously conducted environmental site assessments, asbestos surveys and documents regarding any Release of Hazardous Materials at or from the Leased Real Property.

4.14 Contracts.

(a) Schedule 4.14(a) sets forth, by reference to the applicable subsection of this Section 4.14(a), each Purchased Contract (and in the case of an oral Purchased Contract, the material terms of such Purchased Contract) to which the Seller is a party or to which any of the Purchased Assets are bound:

(i) governing, relating to or evidencing the borrowing of money or the guarantee for the benefit of a third party of Indebtedness by the Seller, or the granting of Liens on any Purchased Asset;

(ii) containing covenants limiting the freedom of the Seller to compete in any line of business or with any Person or in any geographic area or market or not to solicit or hire any Person;

(iii) with any officer or employee of the Seller (other than the Employee Benefit Plans or Retained Assets referred to on Schedule 2.3(n));

(iv) providing for the future or ongoing purchase, maintenance, or acquisition, or the sale or furnishing, of services, materials, supplies, merchandise, or equipment (including computer hardware or software or other property or services) in excess of \$25,000;

(v) granting to any Person a first-refusal, first-offer or similar preferential right to purchase or acquire, in the future, any right, asset, or property of the Seller;

(vi) other than the IRUs or fiber leases disclosed on Schedule 2.2(c) relating to Network Agreements, for the sale or lease of any real property, equipment, or other personal property (where the Seller is the lessor or lessee under any such lease);

(vii) containing a "most favored nation" pricing agreement, any exclusive license or exclusive supply or distribution agreement, or other exclusive rights with a customer or vendor;

(viii) involving a joint venture or partnership or involving the sharing of profits, losses, costs, or liability by the Seller with any other Person;

(ix) involving the acquisition of any business enterprise whether via stock or asset purchase or otherwise, except as expressly contemplated by this Agreement and the Ancillary Agreements;

(x) involving a Material Customer or Material Vendor;

(xi) that is a Government Contract;

(xii) union contracts, collective bargaining agreements, side agreements, or other written agreements between the Seller and any labor organization;

(xiii) under which the Seller has an existing obligation with respect to an “earn out,” contingent purchase price, or similar deferred or contingent payment obligation payable by the Seller;

(xiv) that provides for a change of control, retention or similar payment by the Seller;

(xv) evidencing a capital expenditure or obligation to make any capital commitment in an amount in excess of \$50,000 in the aggregate; or

(xvi) relating to the settlement of any Proceeding, any internal complaint, grievance, claim or investigation, or any other dispute involving the Seller or the Business.

The contracts described in clauses 4.14(a)(i)-(xii), together with the Licenses In and Licenses Out, are each a “**Material Contract**” and collectively, the “**Material Contracts**”. The Seller has provided to the Purchaser true and complete copies of each Material Contract, as amended through the Closing Date.

(b) Except as set forth on Schedule 4.14(b): (i) the Purchased Contracts constitute all of the Contracts adequate and sufficient to permit the Purchaser to conduct the Business as conducted by the Seller immediately prior to the Closing Date; (ii) each Purchased Contract is a valid, binding, and enforceable obligation of the Seller and the other parties thereto, enforceable in accordance with its terms, subject to the General Enforceability Exceptions; (iii) neither the Seller nor, to the Knowledge of the Seller, is any other party thereto in default under or in violation of any Purchased Contract; and (iv) to the Knowledge of the Seller, no event has occurred that, with notice or lapse of time or both, would constitute such a default or violation under any Purchased Contract.

4.15 Permits. Schedule 4.15 sets forth a complete and accurate list and description of all Permits currently held by the Seller. The Seller is in compliance with the terms of such Permits and there is no pending or, to the Knowledge of the Seller, threatened, termination, expiration or revocation thereof. The Seller has not received written notice of any violation of any Permit. All reports required to be filed by or on behalf of the Seller with any Governmental Authority in connection with a Permit have been filed and, to the Knowledge of the Seller, were correct and complete when so filed. Except as set forth and described on Schedule 4.15, the Seller possesses all Permits required to conduct its business as presently conducted. Each Permit set forth on Schedule 4.15 is valid and in full force and effect, and none of such Permits will

lapse, terminate, expire, or otherwise be impaired as a result of the performance of this Agreement by the Seller or the consummation of the transactions contemplated hereby.

4.16 Intellectual Property.

(a) Schedule 4.16(a) sets forth a complete and correct list as of the date hereof of all the following Owned Intellectual Property: (i) patents and applications therefor; (ii) registered copyrights and applications therefor; (iii) registered trademarks and service marks and pending applications for registration of trademarks or service marks and material unregistered trademarks and service marks; and (iv) Internet domain name registrations. All fees associated with filing or maintaining any Owned Intellectual Property have been paid in full in a timely manner to the proper Governmental Authority and, except as set forth on Schedule 4.16(a), no such fees are due within the three (3)-month period after the Closing Date. Each item of Registered Owned Intellectual Property is valid, subsisting, and in full force and effect, and has not been cancelled, expired, or abandoned. No Proceeding is pending or, to the Knowledge of the Seller, threatened challenging the Seller's rights to, or validity or enforceability of, any Owned Intellectual Property, or asserting that upon consummation of the transactions contemplated hereby the Seller's rights to any Owned Intellectual Property will be invalid or unenforceable. The Seller has taken all necessary actions, that must be taken on or prior to the Closing Date, to maintain each item of Registered Owned Intellectual Property that is material to the Business, including payment of maintenance fees, filing of applications for renewal and affidavits of use, or the filing of opposition, interference, or cancellation proceedings before the United States Patent and Trademark Office, the United States Copyright Office, or in any similar Governmental Authority. Seller exclusively owns all Owned Intellectual Property free and clear of all Liens other than Permitted Liens.

(b) Except as set forth on Schedule 4.16(b), the Intellectual Property used by the Seller or otherwise in its possession is sufficient for the conduct of the Seller's business as currently conducted, the Seller has a valid and enforceable right to use or possess, as applicable, such Intellectual Property. Neither the operation of the Business as it is currently conducted by the Seller, nor any activity by the Seller, including the design, development, use, import, branding, advertising, promotion, marketing, manufacture, delivery, sale and/or licensing of any Business product or service, (i) infringes or violates or (ii) in the past infringed or violated, any rights of others in or to any Intellectual Property; provided, however, that the representations and warranties in this Section 4.16(b) are made to the Knowledge of the Seller with respect to the rights of others in or to any patents. To the Knowledge of the Seller, there is no, nor has there been any, infringement or violation of any person or entity of any of the Owned Intellectual Property or the Seller's rights therein or thereto.

(c) Except as set forth on Schedule 4.16(c), no officer or employee of the Seller owns or claims any rights in (nor has any of them made application for) any Owned Intellectual Property. All persons that created, or assisted in the development of the Owned Intellectual Property have assigned all right, title, and interest in that Intellectual Property to the Seller or the Seller is otherwise the owner of such rights.

(d) Except as set forth on Schedule 4.16(d), the Seller has not received any written notice of any claim and there is, to the Knowledge of the Seller, no threatened claim, against the Seller asserting that the Seller has infringed, misappropriated, diluted, violated or otherwise conflicted with any Intellectual Property right of any other Person or that the Owned Intellectual Property infringes, misappropriates, dilutes, violates, or otherwise conflicts with the Intellectual Property of any Person. The Seller has not, within the last three (3) years, given any notice to any Person asserting infringement by such Person of any of the Owned Intellectual Property.

(e) All Information Systems used by the Seller are sufficient for the conduct of the Seller's business as currently conducted. There are no breaches of such Information Systems in the last three (3) years.

(f) Schedule 4.16(f) lists all of the (i) Contracts under which the Seller is granted rights by others in Software and/or Intellectual Property, in each case that is not Owned Intellectual Property (excluding commercially available off-the-shelf software with a per copy or per seat annual license fee of \$10,000 or less) ("**Licenses In**"), and (ii) Contracts under which the Seller has granted rights to others in Owned Intellectual Property (not including customer agreements entered into in the Ordinary Course of Business, substantially in the form of the Seller's form of customer agreement) ("**Licenses Out**"). To the Knowledge of the Seller, there are no problems viruses, worms, time-bombs, key-locks or defects in any Software used by the Seller in its business that could prevent, disrupt or interfere with any such Software or Information Systems from materially operating in fulfillment of its intended purpose or substantially as described in its related documentation or specifications. The Seller uses industry standard methods in the Business to (x) detect and prevent viruses and any third party software routines designed to permit unauthorized access, disable or erase software, hardware or data, or perform any other similar actions that may be present in the Seller's products and services, and (y) subsequently correct or remove such viruses and subroutines. To the Knowledge of the Seller, none of the Software used by the Seller include or install undocumented or unauthorized portals, key-logs, codes, commands or other access to such Software or the data, information or signals the Software produces or processes, or any spyware, adware, or other similar software that monitors the use of the Software or contacts any remote computer without the knowledge and express consent of the user(s) of the applicable Software or remote computer, as applicable. The Seller has obtained and possesses valid licenses to use all of the Software programs that are material to its business and present on the computers it owns or leases that are used in connection with the Business.

(g) The Seller has taken reasonable security measures to protect the confidentiality and value of all Trade Secrets owned or purported to be owned by the Seller.

(h) All Owned Intellectual Property is (i) fully transferable by the Seller to the Purchaser as contemplated by the transactions contemplated in this Agreement and (ii) fully alienable and licensable by the Seller without restriction and without payment of any kind to any third party.

(i) The Seller is currently in compliance with, and at all times within the past three (3) years has complied with, all applicable Privacy Laws. The Seller does not accept any credit cards as a form of payment in the Business. The Seller has a privacy policy that incorporates all disclosures to data subjects required by the Privacy Laws and the privacy policy has been provided to data subjects whose Personal Information is collected, stored or processed by the Seller. None of the disclosures made or contained in such privacy policy has been materially inaccurate, misleading or deceptive or in violation of the Privacy Laws (including containing any material omission).

(j) The Seller has at all times within the past three (3) years implemented all organizational, physical, administrative and technical measures required by Privacy Laws designed to protect Personal Information against data security incidents or other misuse. The Seller has implemented commercially reasonable procedures, satisfying the requirements of applicable Privacy Laws, to detect data security incidents.

(k) The Seller or its agents (i) regularly conducts vulnerability testing, risk assessments, and external audits of, and tracks security incidents related to the Seller's systems, (ii) promptly corrects any material exceptions or vulnerabilities identified, and (iii) promptly installs software security patches and other fixes to identified technical information security vulnerabilities.

(l) In the past three (3) years there have been no data security incidents, personal data breaches or other adverse events or incidents related to Personal Information in the custody or control of the Seller or, to the Knowledge of the Seller, any service provider acting on behalf of the Seller. No breach or violation of the Seller's information security systems has occurred in the past three (3) years or is threatened in writing, and there has been no unauthorized or illegal use of or access to any personal Information. The Seller has a commercially reasonable data breach response plan that it tests on at least an annual basis.

(m) In the past three (3) years there have not been any claims or proceedings related to any data security incidents or any violations of any Privacy Laws, and to the Knowledge of the Seller there are no facts or circumstances that could reasonably serve as the basis for any such allegations or claims, and the Seller has not received any correspondence relating to, or notice of any proceedings, claims, investigations or alleged violations of, Privacy Laws, with respect to Personal Information from any person or governmental authority, and there is no such ongoing proceeding, claim, investigation or allegation.

4.17 Financial Statements.

(a) Attached as Schedule 4.17(a) are correct and complete copies of (i) the audited statements of financial position of the Seller as of December 31, 2019 and 2020, and the related audited statements of activities and the statements of functional expenses for the years then ended, and the other financial information included therewith (collectively, the "*Financial Statements*"), and (ii) the unaudited statement of financial position of the Business as of [MOST RECENT INTERIM FINANCIAL STATEMENTS DATE], 2021 and the related unaudited statement of activities for the [#OF MONTHS]-month period then ended (collectively, the "*Interim Financial Statements*").

(b) Except as set forth on Schedule 4.17(b), (i) the Financial Statements present fairly, in all material respects, the financial position and results of operations of the Seller at the dates and for the time periods indicated and have been prepared by the Seller's auditors in accordance with GAAP, consistently applied throughout the periods indicated, and (ii) the Interim Financial Statements present fairly in all material respects the financial position and results of operations at the date and for the period indicated. The Financial Statements and the Interim Financial Statements were derived from the books and records of the Seller.

4.18 Undisclosed Liabilities. The Seller has no material liabilities, except (a) liabilities reflected in the Interim Financial Statements, (b) liabilities that have arisen after the date of the Interim Financial Statements in the Ordinary Course of Business, or (c) as otherwise set forth on Schedule 4.18.

4.19 Accounts Receivable. All of the Seller's accounts represent sales actually made in the Ordinary Course of Business or valid claims as to which full performance has been rendered by the Seller. All of such accounts are, in the aggregate, collectible in full, net of the reserve therefor, in the Ordinary Course of Business. There are no disputes with respect to any of such accounts receivable. The reserve on the Financial Statements against the accounts receivable for returns and bad debts is adequate and has been calculated in accordance with GAAP. Except as set forth on Schedule 4.19, no counter claims, defenses, or offsetting claims with respect to the accounts receivable of the Seller are pending or, to the Knowledge

of the Seller, threatened. The Seller has not agreed to any deduction, free goods, discount, or other deferred price or quantity adjustment with respect to any of its accounts receivables. All of the Seller's accounts receivable relate solely to sales of goods or services to customers of the Seller, none of which is an employee of the Seller.

4.20 Inventories. The inventories of the Seller are of a quality and quantity useable and saleable in the normal and Ordinary Course of Business and fit for the purpose for which they were procured or manufactured and such inventory is saleable at gross margins consistent with historical practice, subject to appropriate and adequate allowances reflected on the Interim Financial Statements for obsolete, excess, slow-moving, and other irregular items.

4.21 Taxes.

(a) Except as set forth on Schedule 4.21(a), the Seller has timely filed all Tax Returns and timely paid all Taxes to the appropriate Taxing Authority related to the Purchased Assets and the Business. Such Tax Returns are true, correct and complete in all material respects. There are no Liens for Taxes encumbering any of the Purchased Assets.

(b) The Seller has withheld and timely paid to the appropriate Taxing Authority all Taxes required to have been withheld and paid in connection with amounts paid or owing to any employee, independent contractor, creditor, or other third party, and all Forms W-2 and 1099 (or similar reporting form) required with respect thereto have been properly completed and timely filed with the appropriate Taxing Authority.

(c) None of the Purchased Contracts contains a Tax allocation, sharing, indemnification, or similar agreement (other than pursuant to customary commercial contracts the primary purpose of which is not Taxes).

(d) Except as set forth on Schedule 4.21(d), there is no material dispute or claim concerning any Tax of the Seller related to the Purchased Assets or the Business that has been claimed or raised by any Governmental Authority in writing. With respect to the Purchased Assets or the Business, no written claim has ever been made by a Governmental Authority in a jurisdiction where the Seller does not file Tax Returns that the Seller is or may be subject to taxation by that jurisdiction as a result of the operation of the Business in that jurisdiction nor, to the Knowledge of the Seller, is there any factual or legal basis for any such claim. All deficiencies asserted, or assessments made, against the Seller as a result of any examinations by any Taxing Authority with respect to the Purchased Assets or the Business have been fully paid.

(e) None of the Purchased Assets constitutes stock of a corporation (or an entity treated as a corporation for U.S. federal income Tax purposes), an interest in a partnership (or an entity treated as a partnership for U.S. federal income Tax purposes), or any other equity interest in any other entity.

(f) The Seller is not and has never been a party to, or bound by, any Tax indemnity, Tax sharing or Tax allocation agreement (other than pursuant to customary commercial contracts the primary purpose of which is not Taxes).

(g) Except as set forth on Schedule 4.21(g), (i) the Seller has not made any changes to its Tax accounting or reporting, or deferred any payroll Taxes that otherwise would have been required to be remitted or paid in connection with amounts paid by it to any employee or individual

service provider as a result of provisions in the CARES Act, and (ii) has not otherwise taken advantage of any tax benefit or tax program provided by or pursuant to the CARES Act.

4.22 Customers; Vendors.

(a) Schedule 4.22(a) sets forth (i) the Seller's twenty (20) largest customers (listed in order of dollar amount of sales to such customers calculated in accordance with GAAP) for the years ended December 31, 2019 and December 31, 2020 (the "**Material Customers**") and (ii) the dollar amount of sales to such Material Customers. Except as set forth on Schedule 4.22(a), (A) all Material Customers continue to be customers of the Seller and none of such Material Customers has reduced materially its business with the Seller from the levels achieved during the year ended December 31, 2020, and, to the Knowledge of the Seller, there is no reason to believe that any such reduction will occur; (B) no Material Customer has terminated its relationship with the Seller, nor has the Seller received notice, nor to the Knowledge of the Seller is there any other reason to believe, that any Material Customer intends to do so or to materially alter the terms of its relationship with the Seller; (C) the Seller is not involved in any claim, dispute, or controversy with any Material Customer; and (D) no Material Customer has materially reduced, or has requested in writing, or to the Knowledge of the Seller orally, to materially reduce, in either case, in the aggregate, the pricing of any good or service it purchases from the Seller, nor, to the Knowledge of the Seller, is there any other reason to believe that any Material Customer intends to do so.

(b) Schedule 4.22(b) sets forth (i) the Seller's twenty (20) largest vendors (listed in order of the dollar amount purchased from such vendors calculated in accordance with GAAP) for each of the years ended December 31, 2019 and December 31, 2020 ("**Material Vendors**") and (ii) the dollar amount of purchases from such Material Vendors. Except as set forth on Schedule 4.22(b), (A) all Material Vendors continue to be vendors of the Seller and none of such Material Vendors has materially reduced its business with the Seller from the levels achieved during the year ended December 31, 2020, and, to the Knowledge of the Seller, there is no reason to believe that any such reduction will occur; (B) no Material Vendor has terminated its relationship with the Seller, nor has the Seller received notice, nor to the Knowledge of the Seller is there any other reason to believe, that any Material Vendor intends to do so; (C) the Seller is not involved in any claim, dispute, or controversy with any Material Vendor; (D) no Material Vendor has materially increased or requested in writing, or to the Knowledge of the Seller orally, to materially increase, in either case, in the aggregate, the pricing of any good or service it sells to the Seller nor, to the Knowledge of the Seller, is there any other reason to believe that any Material Vendor intends to do so.

4.23 Related Party Transactions. Except as set forth on Schedule 4.23, no officer or employee of the Seller (a) has, or during the last two (2) fiscal years has had, direct or indirect interest (i) in any Person that is a customer, vendor, lessor, creditor, or competitor of the Seller, or (ii) in any material property, asset, or right that is owned or used by the Seller in the Business, or (b) is, or during the last two (2) fiscal years has been, a party to any agreement or transaction with the Seller, other than agreements with employees with respect to employment, compensation, non-disclosure, non-solicitation, non-competition, and/or confidentiality.

4.24 Books and Records. All of the books and records of the Seller have been maintained in the Ordinary Course of Business and fairly and accurately reflect, in all material respects, transactions arising from the Business.

4.25 Product Liability and Warranty.

(a) Each product or service sold, manufactured, or otherwise delivered, as applicable, by the Seller has been in conformity with all applicable contractual commitments, and the Seller has no liability (and, to the Knowledge of the Seller, there is no basis for any present or future Proceeding against the Seller) for replacement or repair of any such products or services or other damages in connection therewith, subject only to the reserve for product and service warranty claims set forth in the Interim Financial Statements. No product sold, leased, licensed, distributed or delivered, and no service provided, by the Seller is subject to any guaranty, warranty, or other indemnity beyond the applicable standard terms and conditions of sale, lease, or service in the Ordinary Course of Business.

(b) The Seller does not have any liability, and to the Knowledge of the Seller, there is no basis for any present or future Proceeding or demand against the Seller giving rise to any such liability, arising out of any injury to Person or property as a result of the ownership, possession, or use of a product or service manufactured, delivered, or provided by the Seller.

4.26 Insurance. Schedule 4.26 sets forth a true and complete list and brief description (including all applicable premiums and deductibles) of all insurance policies to which the Seller is a party or named insured, or under which the Seller or any current officer of the Seller (but solely with respect to such employee's capacity as an employee of the Seller, and not otherwise) is a party, or an insured. All of such insurance policies are in full force and effect, all premiums due and payable with respect to such insurance policies have been paid to date, and the Seller has never been in default with respect to its Liabilities under any such insurance policies. No written notice of cancellation or termination or non-renewal has been received by the Seller with respect to any such policy. The insurance maintained by the Seller is sufficient to comply, in all material respects, with all applicable Laws and Purchased Contracts to which the Seller is a party or by which the Purchased Assets are bound. During the last three (3) years, the Seller has not been refused any insurance.

4.27 Brokers. Other than Houlihan Lokey who has acted as an advisor to the Seller (i) no Person has acted directly or indirectly as a broker, finder, or financial advisor for the Seller in connection with the transactions contemplated by this Agreement and (ii) except as set forth on Schedule 4.27, which such schedule sets forth the name and amount of payment, no other Person is entitled to any fee or commission or like payment in respect thereof based in any way on any agreement, arrangement, or understanding made by or on behalf of the Seller.

4.28 Government Contracts.

(a) With respect to any Contract between the Seller and any Governmental Authority, including any Purchased Contract under which the Seller knowingly agrees to provide goods or services for eventual use by a Governmental Authority (collectively referenced as "**Government Contracts**"): (i) there have been no investigations, external or internal, in connection with any alleged fraud or material contractual noncompliance by or of the Seller; (ii) there has been no suspension or debarment proceeding (or equivalent proceeding, such as a "show cause") against the Seller; and (iii) the Seller is in compliance in all material respects with all statutory, regulatory, and contractual requirements applicable to each Government Contract.

(b) The Seller and its officers and employees have not been debarred, suspended, or otherwise formally rendered generally ineligible for award of Contracts with any U.S. federal Governmental Authority.

4.29 Network.

(a) The Seller has provided to the Purchaser a Google Earth KMZ digital file of a map showing the route and location of the Seller's Network Facilities that comprise the Seller's network (the "**Network**") including, in all material respects, (i) the routes and locations of all fiber optic lines and other cabling owned by the Seller; (ii) the routes and locations of all fiber optic lines and other cabling that the Seller leases or obtains from others; (iii) the number and location of all regeneration sites in the Network Facilities; and (iv) locations (transmitting and receiving) of the Seller's wireless Network Facilities.

(b) The Network Facilities necessary for the conduct of the business of the Seller as presently conducted are in good working order, structurally sound and adequate for the uses to which they are being put (ordinary wear and tear excepted) and, for the portion of the Network owned or maintained by the Seller, are free from any material defect and have been maintained in all material respects in the Ordinary Course of Business.

(c) Schedule 4.29(c) sets forth (i) a description that is true and complete in all material respects of the collocation facilities operated by the Seller as of the date hereof and (ii) a complete list of outages, failures, breakdowns or continuous periods of substandard service or network or collocation service unavailability which was material or resulted in (A) customer service credits greater than Twenty Five Thousand Dollars (\$25,000), (B) cancellation or termination of a customer order or agreement, or (C) required notification to the FCC, in each case, during the two (2) years prior to the date hereof.

(d) Each of the collocation facilities operated by the Seller and the Network are, in all material respects, working, functional and fit for the purpose intended, taken as a whole. The portion of the Network maintained by the Seller has been maintained, subject to ordinary wear and tear, in good working condition for purposes of operating the Business, taken as a whole.

(e) No third party has delivered written notice whereby it challenges or repudiates, or threatens to challenge or repudiate, or asserts the right to terminate or repudiate any Network Underlying Rights, and no property owner or other third party has challenged in writing to the Seller the right of the Seller to install, operate or maintain cable, wires, conduits or other equipment or facilities in a customer or other third party location necessary for the provision of service to existing customers. The Network Underlying Rights constitute some (but not all) of the material rights necessary to run the Network.

(f) The Seller owns or has a valid right to use the Network Underlying Rights free and clear of all Liens arising through the Seller and the Seller and has held all of the Network Underlying Rights in a manner that the Seller does not violate in any material respect the terms of any such Network Underlying Right.

(g) The Seller has the right to use all equipment necessary to operate the Network as currently operated by the Seller. Except as provided in Schedule 4.29(c), other than through the process of eminent domain, no Governmental Authority or other third party has any right to purchase or otherwise acquire or lease the Network owned by the Seller or any material portion thereof, and there is currently no action or proceeding pending or, to the Knowledge of the Seller, threatened, whereby a Governmental Authority or other third party is seeking to purchase or otherwise acquire or lease the Network or any portion thereof.

(h) The Seller has (i) acquired the rights necessary or required for using the Network and (ii) obtained the necessary consent, waiver, approval, authorization or other Permit of, or filing or registration with or notification to any Governmental Authority and rights-of-way, obtained easements and placed conduit, cables and structures in the appropriate locations along the physical Network owned by the Seller as necessary or required. Further, the Seller has adequate rights of access to the buildings and other property included in the Leased Real Property to service its Network Facilities.

4.30 Regulatory Matters. Without limiting any of the other representations or warranties made in this ARTICLE 4:

(a) The Seller holds all Communications Licenses necessary for the Seller to own, lease and operate its Network Facilities or to conduct its business in the manner in which such business is currently being conducted. Schedule 2.2(o) sets forth a true, correct and complete list of all such Communications Licenses. Except as set forth on Schedule 4.30(a), each Communications License is in full force and effect, there are no Proceedings pending, or, to the Knowledge of the Seller, threatened which have resulted or would reasonably be expected to result in any revocation, suspension, default or violation of or with respect to any Communications License, a material condition on the Communications License, or any material fine or forfeiture in connection therewith.

(b) Except as set forth in Schedule 4.30(b), since December 31, 2017, the Seller has operated and conducted its business in all material respects in compliance with the terms and conditions of the Communications Licenses and the Communications Laws, including timely and accurately submitting all material reports, notifications and applications required by applicable Communications Laws, and the payment of all Regulatory Payments.

(c) Except as set forth in Schedule 4.30(c), since December 31, 2017, the Seller has filed all required reports, including FCC Forms 499A and 499Q, and all such filings were, when made or amended, true, correct and complete and in accordance with existing precedent of the relevant Governmental Authority. At the Closing, the Seller shall have paid, or made adequate provision for the payment of, all federal and state Regulatory Payments billed by the FCC, State PUCs, and Fund Administrators and pertaining to the period prior to the Closing Date. At the Closing, the Seller shall have filed all required reports, including FCC Forms 499A and 499Q, that were due prior to the Closing Date, and retained all supporting documentation, necessary for the FCC, State PUCs, and Fund Administrators to calculate their Regulatory Payments. Where such reports are not due to be filed until after the Closing Date, the Seller shall also have compiled and retained all documentation needed to file any reports necessary for the FCC, State PUCs, and Fund Administrators to calculate Regulatory Payments for the period prior to the Closing Date. Since December 31, 2017, the Seller has not been the subject of any audit, investigation, enforcement, Proceeding, assessment, fine, penalty or interest related to Universal Service Subsidies or Regulatory Payments and, to the Knowledge of the Seller, no such audit, investigation, enforcement, Proceeding, fine, penalty or interests is threatened.

(d) The Seller has not deployed or, to the Knowledge of the Seller, used Network Facilities or other communications equipment and services that are on the FCC's covered list of equipment and services covered by Section 2 of the Secure Networks Act, including Huawei or ZTE.

4.31 Certain Business Practices.

(a) Since December 31, 2017, none of the Seller or any of its employees or, to the Knowledge of the Seller, any non-employee representatives on its behalf, has (a) used any funds for unlawful contributions, gifts, entertainment or other unlawful expenses relating to political activity; (b) made any unlawful payment or unlawfully given, offered, promised, or authorized or agreed to give, any money or thing of value, directly or indirectly, to foreign or domestic government officials or employees or to foreign or domestic political parties or campaigns; (c) violated any provision of the Foreign Corrupt Practices Act of 1977, as amended, the UK Bribery Act of 2010, or any rules or regulations thereunder, or the provisions of any anti-bribery, anti-corruption and anti-money laundering laws of each jurisdiction in which the Seller operates, or any comparable foreign law or statute; (d) directly or indirectly taken any action in violation of any export restrictions, anti-boycott regulations, embargo regulations or other similar applicable United States or foreign applicable Laws; or (e) engaged in any business with any Person with whom, or in any country in which, it is prohibited for a United States Person to engage under applicable Law or under applicable United States sanctions administered by the Office of Foreign Assets Control, except as permitted by applicable Law.

(b) To the Knowledge of the Seller, the Seller has not engaged in unfair competition or trade practices or any false or misleading advertising practices under the Laws of any jurisdiction in which the Seller operates or markets any of its products or services.

(c) To the Knowledge of the Seller, the Seller, during all times as to which the applicable statute of limitations has not yet expired, has complied in all material respects with all International Trade Laws applicable to the Seller. Without limiting the foregoing and in each case to the Knowledge of the Seller:

(i) the Seller has obtained, and is in compliance in all material respects with, all export licenses, license exceptions and other consents, notices, waivers, approvals, orders, authorizations, registrations, declarations, classifications and filings with any Governmental Authority required for (A) the export and re-export of products, services, software and technologies and (B) releases of technologies and software to foreign nationals located in the United States and abroad ("*Export Approvals*");

(ii) there are no pending claims against the Seller with respect to such Export Approvals;

(iii) no Export Approvals with respect to the Seller and the transactions contemplated hereby are required;

(iv) the Seller has not received written notice that the Seller, its directors, officers or employees, in each case in their capacity as such, is a Sanctions Target;

(v) for the past five (5) years, the Seller has not received written notice to the effect that a Governmental Authority claimed or alleged that the Seller was not in compliance with International Trade Laws;

(vi) the Seller has not made any voluntary disclosures to, or has been subject to any fines, penalties or sanctions from, any Governmental Authority regarding any past violations of International Trade Laws; and

(vii) during the past five (5) years, the Seller has not marked or advertised any products as “Made in the USA,” “Made in America,” or otherwise promoted products using equivalent markings, including American flag symbols.

4.32 Disclosure. Neither this Agreement nor any of the Ancillary Agreements, including their respective schedules and exhibits, contains any untrue statement of material fact by the Seller or omits a material fact necessary to be disclosed by the Seller to make each such statement contained herein or therein not misleading.

ARTICLE 5: Representations and Warranties of the Purchaser

The Purchaser hereby represents and warrants to the Seller as follows:

5.1 Existence and Good Standing. The Purchaser is a corporation duly formed, validly existing and in good standing under the laws of the State of Delaware, and is duly qualified to do business as a foreign limited liability company and is in good standing in the jurisdictions set forth on Schedule 5.1, which are the only jurisdictions in which the Purchaser is required to be so qualified.

5.2 Power. The Purchaser has the power and authority to (a) own, operate, and lease its properties and assets as and where currently owned, operated, and leased, and (b) carry on its business as currently conducted. The Purchaser has the power and authority to execute, deliver, and perform its obligations under this Agreement and the Ancillary Agreements.

5.3 Enforceability. The execution, delivery, and performance of this Agreement and the Ancillary Agreements, and the consummation of the transactions contemplated hereby and thereby, have been duly and validly authorized by all necessary action on the part of the Purchaser. This Agreement and each of the Ancillary Agreements have been duly executed and delivered by the Purchaser, and constitute the valid and legally binding obligations of the Purchaser, enforceable against the Purchaser in accordance with their terms, subject to General Enforceability Exceptions.

5.4 No Conflict. Neither the execution of this Agreement or the Ancillary Agreements, nor the performance by the Purchaser of its obligations hereunder, nor the consummation of the transactions contemplated hereby will (a) assuming all Regulatory Consents have been obtained or made, violate any Law or Order applicable to the Purchaser; or (b) violate or conflict with the Purchaser’s organizational documents.

5.5 Consents. Except as set forth on Schedule 5.5, no Consent is required in connection with the execution and delivery by the Purchaser of this Agreement or the Ancillary Agreements or the consummation of the transactions contemplated hereby or thereby.

5.6 No Financing Contingency. The Purchaser’s obligations under this Agreement are not subject to or conditioned upon obtaining any funds or financing from third parties. The Purchaser has, or will have at Closing, all necessary funds on hand to discharge its obligations under this Agreement, including under Section 3.1(b) and Section 7.2(e)(i).

5.7 Brokers. No Person has acted directly or indirectly as a broker, finder, or financial advisor for the Purchaser in connection with the transactions contemplated by this Agreement, and no Person is entitled to any fee or commission or like payment in respect thereof based in any way on any agreement, arrangement, or understanding made by or on behalf of the Purchaser.

ARTICLE 6: Covenants

6.1 **Conduct of Business.** Except as otherwise required by any Law or as contemplated by this Agreement, until the Closing, the Seller shall operate the Business in the Ordinary Course of Business. The Seller will use best efforts to (i) preserve the Business intact, including preserving existing relationships with suppliers, customers, and others having business dealings with the Seller; (ii) keep available the services of its employees; and (iii) continue to carry insurance with respect to the Business in such amounts and with respect to such risks as has been historically carried. The Seller shall not take actions or engage in transactions outside the Ordinary Course of Business without first notifying the Purchaser. Without limiting the foregoing, except as otherwise required by any Law or as permitted by this Agreement, until the Closing, the Seller will not, without the prior written consent of the Purchaser, which such consent will not be unreasonably withheld, delayed or denied:

(a) make any sale, assignment, transfer, conveyance, abandonment, or other disposition of any of the Purchased Assets, except for dispositions of inventory or worn-out or obsolete equipment for fair or reasonable value in the Ordinary Course of Business;

(b) subject any of the Purchased Assets, or any part thereof, to any new Lien except Permitted Liens;

(c) enter into any Material Contract or agreement or series of related contracts or agreements, or make any commitment, whether directly or indirectly by way of guarantee or otherwise, for an expenditure relating to the Business that is not in the Ordinary Course of Business or, except in the Ordinary Course of Business, make any material amendment of or terminate any Purchased Contract;

(d) fail to use commercially reasonable efforts in accordance with the Ordinary Course of Business to maintain the Purchased Assets in good condition and repair, reasonable wear and tear excepted;

(e) fail to maintain its records in the usual, regular and ordinary manner consistent with past practices or materially change its accounting or cash management practices or policies or its application thereof, except as required by GAAP or other accounting or financial reporting rules and regulations, provided that, in the event of any such required change, the Seller shall promptly notify the Purchaser thereof in writing;

(f) except as may be required by any Law and normal increases in the Ordinary Course of Business, materially increase benefits or compensation or otherwise, or grant any bonus or retention or severance pay to any of the Seller's employees, except for bonuses, retention and severance pay that will be fully paid by the Seller; provided, in each case, that the Seller informs the Purchaser prior thereto;

(g) except in the Ordinary Course of Business, sell, transfer, or lease any Purchased Asset;

(h) terminate, fail to renew, abandon, cancel, let lapse, fail to continue to prosecute or defend, sell, transfer, exclusively license, as may be applicable, or otherwise dispose of any of the Owned Intellectual Property;

(i) acquire or agree to acquire by merging or consolidating with, or by purchasing substantially all assets or any equity securities of, or by any other manner, any Person or otherwise

acquire or agree to acquire any material assets in excess of \$100,000 and not in the Ordinary Course of Business;

- (j) waive or release any material right or claim of the Business;
- (k) adopt a plan or agreement of complete or partial liquidation, dissolution, restructuring, recapitalization, merger, consolidation or other reorganization;
- (l) initiate or settle any Proceeding relating to the Business or any Purchased Asset, or pay, discharge or satisfy any Liabilities in connection with any Proceeding in an amount in excess of \$20,000 individually or \$50,000 in the aggregate;
- (m) with respect to the Purchased Assets or the Business, (i) amend any Tax Return, (ii) enter into any “closing agreement” as described in Section 7121 of the Code (or any similar provision of state, local or foreign Law) with any Tax authority with respect to a Tax, (iii) settle any claim or assessment in respect of any Tax, or (iv) consent to any extension or waiver of the limitation period applicable to any claim or assessment in respect of any Tax that would give rise to any claim or assessment of Taxes;
- (n) amend or modify the Seller’s organizational documents;
- (o) revalue any of the Purchased Assets (whether tangible or intangible);
- (p) enter any new agreement or contract to own or operate any Telecommunications Service, Information Service, or fiber optic cable serving any military installation; or
- (q) commit to do any of the foregoing.

6.2 Access to Information.

(a) Until the Closing, the Seller will (i) allow the Purchaser and its authorized representatives reasonable access, upon reasonable prior notice to the Seller, during regular business hours and consistent with the normal operation of the Seller, to the Purchased Assets and the Seller’s books and records and to officers and employees of the Seller for purposes of providing Purchaser with information regarding the Seller’s operations, (ii) allow the Purchaser and its authorized representatives reasonable access, upon reasonable prior notice to the Seller, during regular business hours and consistent with the normal operations of the Seller, to the GPW Maintained Huts for the purpose of conducting Phase I Environmental Site Assessments (the “*Phase I ESAs*”) and (iii) furnish the Purchaser with such financial and operating data and other information with respect to the Seller as the Purchaser may reasonably request, except to the extent that furnishing such information would violate any legal obligation of the Seller.

(b) After the Closing, the Seller will allow the Purchaser and its authorized representatives reasonable access, upon reasonable prior notice to the Seller, during regular business hours and consistent with the normal operation of the Seller, to the Seller’s books and records for any purpose reasonably related to the Purchaser’s interest in the Purchase Assets or the Assumed Liabilities.

(c) After the Closing, the Purchaser will allow the Seller and its authorized representatives reasonable access, upon reasonable prior notice to the Purchaser, during regular business hours and consistent with the normal operation of the Purchaser, to the Purchaser’s books

and records for any purpose reasonably related to the Seller's interest in the Retained Assets, the Retained Liabilities, or otherwise with respect to the Seller's obligations under this Agreement and the Ancillary Agreements. Such access shall not be provided to the extent it would (i) violate applicable Law or (ii) cause the Purchaser to waive any attorney-client privilege with respect to such books and records.

6.3 Fulfillment of Conditions. Subject to the terms of this Agreement and fiduciary obligations under Law, Seller and Purchaser will do all such commercially reasonable acts and things as may be required to satisfy the covenants and obligations under this Agreement and to consummate and complete the transactions contemplated by this Agreement.

6.4 Interim Financial Statements. As promptly as practicable following each regular accounting period subsequent to the end of the dates and periods covered by the Interim Financial Statements and prior to the Closing Date, the Seller shall deliver to the Purchaser periodic financial reports in the form that it customarily prepares for its internal purposes concerning the Business and, if available, financial statements similar in form to unaudited statements of the financial position of the Business as of the last day of each accounting period (beginning and through) and statements of income and changes in cash flows of the Seller for the monthly and year-to-date periods then ended. Such Interim Financial Statements shall be compiled by the Seller's customary auditor and the written report of such compilation shall be delivered to the Purchaser. The Interim Financial Statements and financial statements will not include the related notes to the Financial Statements.

6.5 Notification to Changes. If at any time prior to the Closing either party learns that (i) the occurrence or existence of any fact, event or circumstance that, with respect to such party or the Purchased Assets, has had or would reasonably be expected to have a Material Adverse Effect or (ii) any of its representations or warranties in this Agreement were untrue when made, or would be untrue if made at any time after the date of this Agreement up until the Closing, in any material respect (or with respect to those representations and warranties qualified by materiality, untrue, after consideration of such qualifier, in any respect), such party will give the other party prompt written notice thereof (and will subsequently keep the other informed on a reasonably current basis of any material developments related to such notice).

6.6 Evidence of Lien Terminations. The Seller will provide to the Purchaser at the Closing evidence reasonably satisfactory to the Purchaser that all Liens (other than Permitted Liens) affecting or encumbering the Purchased Assets have been terminated.

6.7 Consents. As soon as reasonably practicable after the date of this Agreement, the Seller shall, for the remaining term of each Purchased Contract, use reasonable best efforts to (i) obtain the Consents of the applicable third parties thereto (and the Purchaser shall jointly work with the Seller to so obtain such Consents), (ii) make the benefit of such Purchased Contract available to the Purchaser following the Closing, and (iii) enforce following the Closing, at the request of the Purchaser and at the expense and for the account of the Purchaser, any right of the Seller arising from such Purchased Contract against the other party or parties thereto (including the right to elect to terminate any such Purchased Contract in accordance with the terms thereof). The Seller will not take any action that would limit or restrict or terminate the benefits to the Purchaser of any Purchased Contract unless, after consultation with the Purchaser, the Seller is ordered in writing to do so by a Governmental Authority of competent jurisdiction or the Seller is otherwise advised by counsel that it is required to do so by Law; provided that if any such order or requirement is appealable, the Seller will, at the Purchaser's cost and expense, take such actions as are requested by the Purchaser to file and pursue such appeal and to obtain a stay of such order. With respect to any Purchased Contract for which the Consent of the applicable third party or parties thereto is obtained after the Closing, the Seller shall transfer and assign such Purchased Contract to the Purchaser by

delivery of an agreement in the form of the Assumption Agreement, but addressing that particular Purchased Contract only, within five (5) business days following receipt of such Consent.

6.8 Regulatory Consent.

(a) As soon as reasonably practicable after the date of this Agreement, but in any event no later than thirty (30) calendar days from the date hereof, (i) the parties hereto will jointly prepare (in consultation and cooperation with each other) and file or submit all initial filings required to be made for the FCC Approvals and the State PUC Approvals and other Governmental Regulatory Approvals as set forth on Schedule 6.8(a)(i), and (ii) the Purchaser shall prepare and submit all initial filings required to be made to obtain any necessary Communications License not otherwise assigned to the Purchaser (the “*Purchaser Communications Licenses*”) as set forth on Schedule 6.8(a)(ii). Each party will promptly file any additional information requested by any Governmental Authority as soon as practicable after receipt of any request for additional information. The parties will cooperate fully with each other in all reasonable respects in promptly seeking to obtain the Regulatory Consents. Each party will have the right to review and approve the other party’s filings with Governmental Authorities with respect to this Section 6.8, in advance, with such approvals not to be unreasonably withheld or delayed. Each party will coordinate and cooperate with one another in exchanging such information and providing such reasonable assistance as may be requested in connection with such filings. Each party will promptly supply the other party with copies of all non-confidential correspondence, filings, or communications (or memoranda setting forth the substance thereof) between such party or its representatives and any Governmental Authority or members of such Governmental Authorities’ respective staffs with respect to any FCC Approvals, State PUC Approvals or Governmental Regulatory Approvals. No party will take in bad faith any action that would have the effect of delaying, impairing, or impeding the receipt of any Regulatory Consents.

(b) The Seller and the Purchaser will agree on forms of request for the Regulatory Consents. Each party will employ commercially reasonable efforts to promptly request and obtain each Regulatory Consent that such party is required to obtain as indicated on Schedule 7.1(c) for the Purchaser and Schedule 7.2(c) for the Seller, using the appropriate agreed-upon form, and the parties will cooperate with each other in all commercially reasonable respects to obtain each Regulatory Consent. Each party shall promptly notify the other if, in connection with obtaining any Regulatory Consent, a Governmental Authority or other Person seeks to impose any condition on or change to any Communications License or Purchased Asset (any such condition or change being referred to as a “*Consent Condition*”). Without the Purchaser’s prior written consent, which may be withheld in Purchaser’s sole discretion, the Seller shall not agree to any Consent Conditions other than monetary Consent Conditions that the Seller will satisfy prior to the Closing.

(c) On or before April 1, 2022, the Seller shall file a “closing” FCC Form 499-A with the Fund Administrator with respect to taxable periods (and portions thereof) between January 1, 2021 and the Closing Date. The Seller shall be solely responsible for the payment (or reimbursement, if applicable) of any and all Universal Service Contributions with respect to the Business (including state and federal Universal Service Contributions) that are due as of the Closing Date or become due at any time thereafter (whether as a result of the filing of such Form 499-A, any other action or “true up,” or for any other reason) relating to taxable periods (or portions thereof) ending on or prior to the Closing Date. From the Closing Date until the Filer ID Deactivation Form is submitted, the Seller shall file FCC Form 499-Q for each quarter and report no projected revenue for the upcoming quarter. On or before April 1, 2022, the Purchaser shall file a Form 499-A that includes the revenue of the Business for service provided after the Closing Date. The Purchaser shall be responsible for, and receive the benefit of (to the extent applicable), any

Universal Service Contributions and any and all credits relating thereto (whether arising as a result of a “true-up” or for any other reason) with respect to the Business that relate to taxable periods (or portions thereof) after the Closing Date. No later than 30 days after the Closing Date, the Seller and the Purchaser shall file with the Fund Administrator a Filer ID Deactivation Form, Sale of One Entity to Another (or such successor filing that may exist on that date) indicating that the Purchaser included or will include revenues on FCC Form 499- Q from the Business for the first period following the Closing Date.

(d) As soon as practicable after the execution of this Agreement, the parties hereto will jointly prepare and file or submit (i) all filings required to be made with the Fund Administrators to assign to the Purchaser, for periods after the Closing Date, commitments for Universal Service Subsidies made to the Seller and (ii) all notices required to be made to customers served with Universal Service Subsidies. The Purchaser shall have primary responsibility for preparing the filings and notices. Each party hereto will promptly file any additional information requested by the Fund Administrators or customers as soon as practicable after receipt of a request for additional information. The parties hereto will cooperate fully with each other and any applicable Fund Administrator or customer in all reasonable respects in promptly seeking to make or obtain the assignments. Each party hereto will have the right to review and approve in advance, with such approvals not to be unreasonably withheld, conditioned or delayed, all filings with the Fund Administrators to be made jointly or by the other party in connection with the transactions contemplated by this Agreement. Each party hereto will coordinate and cooperate with one another in exchanging such information and providing such reasonable assistance as may be requested in connection with such filings, but the Purchaser will not be required to agree to any changes in, or the imposition of any condition on, any Universal Service Subsidies as a condition to obtaining any assignment if such change in or the imposition of any condition on the Universal Service Subsidies would result in a Material Adverse Effect. Each party hereto will promptly supply the other with copies of all nonconfidential correspondence, filings or communications (or memoranda setting forth the substance thereof) between such party or its representatives and any Fund Administrator or members of their respective staffs with respect to this Agreement or the transactions contemplated by this Agreement. Notwithstanding anything to the contrary in this Section 6.8(d), materials provided to the other party or its counsel may be redacted to remove competitively sensitive material, as well as information otherwise not germane to regulatory review.

6.9 Further Assurances. From time to time after the Closing, each party, upon the request of the other party and without further consideration, will execute, deliver, and acknowledge all such instruments of transfer and conveyance and do and perform all such other acts and things as either party may reasonably require to carry out the intent of this Agreement.

6.10 Supplements to Disclosure Schedules. From time to time after the date of this Agreement and up to the Closing Date, the Seller may supplement or amend any Schedules that it delivered on the date hereof with respect to any matter first existing or occurring following the date hereof which, if existing or occurring as of the date hereof, would have been required to be set forth or described in such Schedules delivered on the date hereof (a “*No-Fault Change*”). For purposes of Seller’s obligation to indemnify the Purchaser Indemnified Parties pursuant to Section 10.1(a), no matter constituting a No-Fault Change shall be deemed a breach of any representation or warranty made by the Seller as of the date of this Agreement or as of the Closing.

6.11 Employee Matters.

(a) Not less than fifteen (15) days prior to the Closing Date, the Purchaser will make offers of employment to all employees of the Seller on terms and conditions that are no less

favorable in the aggregate with respect to each individual employee's terms and conditions, to each employee's current employment terms and conditions and only to the extent disclosed to Purchaser as of the date of this Agreement. Any such employee who shall have (i) accepted such offer of employment by the Purchaser and (ii) not rescinded it on or before the Closing Date (each a "**Transferred Employee**," and collectively, the "**Transferred Employees**") shall be deemed to have resigned his or her employment with Seller effective as of the Closing Date. No offers of employment by the Purchaser shall be subject to any conditions other than as set forth in this Section 6.11(a) and the Purchaser's usual and customary hiring procedures, which shall be in conformance with all Laws. The Seller shall retain responsibility for the payment of any employee benefits or entitlement, including severance pay, accrued vacation, sick or holiday pay, to any Transferred Employee or any other employee of the Seller pursuant to any Employee Benefit Plan, applicable Law, or otherwise as a result of or in connection with the consummation of the transactions contemplated hereby.

(b) The Purchaser shall provide Transferred Employees with the ability to participate in employee benefit plans, programs, policies, and arrangements of the Purchaser (the "**Purchaser Plans**") and to receive benefits under the Purchaser Plans commensurate with the Purchaser's obligations under Section 6.11(a). The Purchaser shall not assume (i) any accruals prior to the applicable hire date of each Transferred Employee for unused vacation or (ii) any short-term disability salary continuation payment obligations, or long-term disability payment obligations for any Transferred Employee who is receiving long-term disability payments from the Seller at the time of the Closing Date. The Seller will pay Transferred Employees for such pre-Closing accruals for unused vacation at the Closing.

(c) The Seller will have full responsibility and liability for offering and providing "continuation coverage" to any "covered employee" of the Seller's employees, and to any "qualified beneficiary" of such employees, and who is in each case covered by a "group health plan" sponsored or contributed to by the Seller to the extent that such continuation coverage is required to be provided by the Seller under Section 4980B of the Code and the regulations promulgated thereunder as a result of a "qualifying event" experienced by such covered employee or qualified beneficiary with respect to or in connection with the transactions contemplated by this Agreement. "Continuation coverage," "covered employee," "qualified beneficiary," "qualifying event" and "group health plan" all will have the meanings given such terms under Section 4980B of the Code and Section 601 et seq. of ERISA.

(d) The Seller will be responsible for the maintenance and distribution of benefits accrued up to the Closing Date under the Seller's employee benefit plan or employee program, including any 401(k) plan maintained by the Seller, pursuant to the provisions of such plans and programs and any Law. The Purchaser will not assume any obligation or liability for any such accrued benefits or any fiduciary or administrative responsibility to account for or dispose of any such accrued benefits under any employee benefit plan or employee program. The Seller shall take such action as is necessary to provide that all Transferred Employees who are participants in the Seller's 401(k) Plan (the "**Seller 401(k) Plan**") have a fully vested and nonforfeitable interest in their entire respective account balances under such plan as of the Closing Date (regardless of their years of vesting credit under the Seller 401(k) Plan). On or prior to the Closing Date, with respect to all of the Transferred Employees, the Seller shall contribute all contributions to the Seller 401(k) Plan (i) which are required to be made on or before the Closing Date under the Seller 401(k) Plan, and (ii) which relate to service or employee salary deferral contributions on or prior to the Closing Date, whether or not required to be made on prior to the Closing Date under the Seller 401(k) Plan.

(e) The Seller shall permit the Purchaser to contact and make arrangements with the Seller's employees regarding employment or prospective employment by the Purchaser not more than fifteen (15) days prior to the Closing and for the purpose of ensuring the continuity of the Business, and the Seller agrees not to discourage any such employees from having contact with the Purchaser. The Seller shall make available to the Purchaser such personnel and similar information as the Purchaser may request with respect to any Transferred Employee, including compensation and employment records, in accordance with Law. The Seller shall use its best efforts to keep available the services of its present employees through the Closing Date.

(f) Except as specifically set forth in this Agreement, (i) the Purchaser shall not be obligated to assume, continue or maintain any of the Employee Benefit Plans; (ii) no assets or Liabilities of the Employee Benefit Plans shall be transferred to, or assumed by, the Purchaser or the Purchaser's benefit plans; and (iii) the Seller shall be solely responsible for funding and/or paying any benefits under any of the Employee Benefit Plans, including any termination benefits and other employee entitlements accrued under such plans by or attributable to employees or former employees of the Seller.

(g) Nothing in this Section 0 or elsewhere in this Agreement will be deemed to make any of the Seller's employees third party beneficiaries of this Agreement. Nothing in this Agreement, whether express or implied, shall (i) confer upon any employee of the Seller, or any representative of any such employee, any rights or remedies, including any right to employment or continued employment for any period or terms of employment, of any nature whatsoever, (ii) be interpreted to prevent or restrict the Purchaser or its Affiliates from modifying or terminating the employment or terms of employment of any Transferred Employee, including the amendment or termination of any employee benefit or compensation plan, program or arrangement, after the Closing Date or (iii) be treated as an amendment or other modification of any employee benefit plan or arrangement.

6.12 Tax Matters.

(a) Each of the Purchaser and the Seller will cooperate fully, as and to the extent reasonably requested by the other party, in connection with the filing of Tax Returns and any audit, litigation or other proceeding with respect to Taxes related to the Purchased Assets and the Business. Such cooperation will include the retention and, upon the other party's request, the provision of records and information that are reasonably relevant to any such audit, litigation, or other proceeding and making employees available on a mutually convenient basis to provide additional information and explanation of any material provided hereunder. The Purchaser and the Seller will (i) retain all books and records with respect to Tax matters pertinent to the Purchased Assets and the Business relating to any taxable period beginning before the Closing Date until the expiration of the statute of limitations (and, to the extent notified by the Purchaser or the Seller, any extensions thereof) of the respective taxable periods, (ii) abide by all record retention agreements entered into with any Taxing Authority with respect to the Purchased Assets and the Business, and (iii) give the other party reasonable written notice prior to transferring, destroying, or discarding any such books and records and, if the other party so requests, allow the other party to take possession of such books and records.

(b) All transfer, documentary, sales, use, stamp, registration, value added and other similar Taxes, and all conveyance fees, recording charges, and other charges and fees (including with respect to each, any penalties and interest) incurred in connection with consummation of the transactions contemplated by this Agreement ("**Transfer Taxes**") are to be borne and timely paid by the Seller when due, and Tax Returns relating to Transfer Taxes shall be prepared by the Seller,

at its own expense, and filed by the party responsible for filing such Tax Return under applicable Law. The Seller shall provide the Purchaser with copies of all Tax Returns for Transfer Taxes and evidence that such Transfer Taxes have been paid. If the Purchaser is required by Law to remit payment for Transfer Taxes, the Seller shall promptly reimburse the Purchaser for any such Transfer Taxes actually paid by the Purchaser. The parties hereto and their Affiliates shall cooperate in connection with the filing of any such Tax Returns for Transfer Taxes including joining in the execution of such Tax Returns for Transfer Taxes and in obtaining all available exemptions from such Transfer Taxes.

6.13 Risk of Loss. The risk of loss with respect to the Purchased Assets shall remain with the Seller until the Closing. Until the Closing, the Seller shall maintain in force all the policies of property damage insurance under which any of the Purchased Assets is insured. In the event prior to the Closing any Purchased Asset is lost, damaged, or destroyed and the loss, damage, or destruction would result in a Material Adverse Effect, then:

(a) the Purchaser may terminate this Agreement in accordance with the provisions of Section 9.1(b)(ii); or

(b) the Purchaser may require the Seller to assign to the Purchaser the proceeds of any insurance payable as a result of the occurrence of such loss, damage, or destruction and to reduce the Purchase Price by the amount of the replacement cost of the Purchased Assets that were lost, damaged, or destroyed less the amount of any proceeds of insurance payable as a result of the occurrence.

6.14 Financing Cooperation.

(a) Until the Closing, the Seller shall provide, and shall use its commercially reasonable efforts to cause each of its officers, directors, managers, representatives and advisors to provide all cooperation to the Purchaser, at the Purchaser's sole cost and expense, as reasonably requested by the Purchaser in connection with obtaining and consummating debt financing for the purpose of consummating the transactions contemplated by this Agreement (the "**Debt Financing**"), including the following: (i) facilitating the obtaining of guarantees, the pledging of collateral and the granting of security interests (and the perfection thereof) in any collateral and assisting with the preparation of definitive loan documentation (including perfection certificates and schedules), including executing and delivering any customary definitive loan and security documents, instruments and customary closing certificates as may be reasonably requested by the Purchaser (provided that any such documents or certificates and any obligations contained in such documents shall be subject to the occurrence of, and effective no earlier than, the Closing); (ii) at least three (3) business days prior to Closing, providing all documentation about the Seller that is reasonably requested by the Purchaser in writing at least nine (9) business days prior to Closing and which is required by applicable "beneficial ownership," "know your customer" and anti-money laundering rules and regulations including the USA PATRIOT Act; (iii) furnishing to the Purchaser as promptly as practicable (A) the Financial Statements and (B) all other customary and readily available financial and other pertinent information reasonably requested by the Purchaser regarding the Seller customarily required in connection with the Debt Financing; (iv) causing the Seller's senior officers to participate on reasonable advanced notice and at reasonable locations in a reasonable number of meetings and presentations with actual or prospective lenders and due diligence sessions (and providing customary diligence materials reasonably requested by the Purchaser); (v) providing financial information and other data regarding the Seller reasonably required or requested in connection with the preparation of any pro forma financial statements required in connection with the Debt Financing; (vi) requesting and providing drafts of the payoff

letters, lien releases and other termination notices and delivering (by the date required under the agreements governing such Indebtedness) any notices (including notices of prepayment) required in connection with the prepayment, payoff, discharge and termination in full at and subject to the occurrence of Closing of all Indebtedness required by this Agreement to be repaid at Closing; and (vii) promptly upon becoming aware thereof, supplementing the written information concerning the Seller furnished pursuant to this Section 6.14 to the extent any such information contains any untrue statement of a material fact regarding the Seller, or omits to state any material fact regarding the Seller necessary to make the statements contained therein not misleading under the circumstances under which such statements were made.

(b) Notwithstanding anything in this Agreement to the contrary, neither the Seller nor its directors, officers, managers, members, employees, equityholders, representatives and Affiliates shall (i) be required to pay any commitment or other similar fee in connection with the Debt Financing, (ii) have any liability or obligation under the definitive loan documentation for the Debt Financing, (iii) be required to take any action that would (A) violate or result in a material breach of or material default under this Agreement, any Material Contract, any organizational documents of the Seller or any applicable Law binding on the Seller or (B) unreasonably interfere with the ongoing business of the Seller; provided, that, in the event the Seller does not take an action in reliance on this clause (iii), the Seller shall inform the Purchaser thereof and of the general nature of the information being withheld, or (iv) be required to (A) prepare or deliver any financial statements for any period that are not otherwise available or prepared in the Ordinary Course of Business or any pro forma financial statements, (B) execute or deliver any certificate, document or agreement in connection with the Debt Financing unless the effectiveness of such certificate, document or agreement is contingent upon the occurrence of the Closing, (C) deliver or cause its counsel to deliver any legal opinion letters in connection with the Debt Financing, (D) take any action that would subject any officer, director or manager of the Seller to any personal liability with respect to any matters relating to the Debt Financing or (E) provide access to, or disclose any information to, the Purchaser or any of the Purchaser's representatives if such access or disclosure would reasonably be expected to result in waiving any attorney-client privilege; provided that if the Seller so withholds any reasonably requested access or disclosure of any information from the Purchaser, it shall notify the Purchaser in writing that disclosure or information has been withheld and of the general nature of the disclosure or information being withheld.

(c) The Purchaser shall promptly upon written request by the Seller following the termination of this Agreement pursuant to and in accordance with ARTICLE 9: hereof (other than by reason of a breach of this Agreement by the Seller), reimburse the Seller for all fees and reasonable and documented out-of-pocket expenses (including reasonable and documented legal and accounting fees and expenses) incurred by the Seller or its representatives in connection with providing the assistance contemplated by this Section 6.14 (it being understood and agreed, however, that the Seller (and not the Purchaser) shall be responsible for (i) ordinary course amounts payable to existing employees of the Seller and (ii) any such amounts incurred by the Seller that would have been incurred by the Seller in connection with the transactions contemplated hereby regardless of the Debt Financing (including the preparation and delivery of the Financial Statements, payoff letters and lien releases).

6.15 MEAG Office Lease and MEAG Rights and Assets. (a) If Seller's then existing lease with MEAG for the space located at 1470 Riveredge Parkway, Atlanta, GA 30328 (the "**MEAG Office Lease**") is on the same terms as those terms in effect as of the date of execution of this Agreement and the term of the MEAG Office Lease has not been extended for a period in excess of twelve (12) months after the date of Closing, then the Purchaser shall enter into an assignment and assumption of the MEAG Office Lease, so long as MEAG shall have consented to such assignment and assumption and (b) the Purchaser shall have

entered into one or more agreements with MEAG to acquire the MEAG Rights and Assets on commercially reasonable terms, in each case of (a) and (b) to be effective as of the Closing.

6.16 Universal Service Fund Certifications. Seller shall request and take commercially reasonable actions to obtain a USF Jurisdictional Certification in the form set forth on Schedule 6.16 from each of Seller's end user customers that purchases Telecommunications circuits with both end points within the same state.

ARTICLE 7: Conditions to Closing

7.1 Of the Purchaser. Subject to the provisions of Section 7.1(i), the obligations of the Purchaser to proceed with the transactions contemplated by this Agreement are subject to the satisfaction, on or prior to the Closing Date, of the following conditions:

(a) *Representations and Warranties of the Seller*. (i) the representations and warranties of the Seller set forth in Section 4.1 (Existence; Good Standing and Capitalization), Section 4.2(Power), Section 4.3 (Enforceability), Section 4.7 (Necessary Property), Section 4.13 (Environmental) and Section 4.27 (Brokers) shall have been true and correct in all material respects as of the date of this Agreement and shall be true and correct in all material respects as of the Closing Date as if made on the Closing Date (except to the extent that any such representation or warranty expressly speaks as of an earlier date, in which case such representation and warranty shall be true and correct only as of such earlier date) and (ii) the representations and warranties of the Seller set forth in ARTICLE 4: (other than those described in the foregoing clause (i)) shall have been true and correct as of the date of this Agreement and shall be true and correct (without giving effect to any qualifications or limitations as to "materiality," "Material Adverse Effect" or words of similar import) on the Closing Date, in each case taking into consideration any of the changes referred to in Section 6.10, except (A) for a representation and warranty that expressly speaks only as of a specific date or time, which need only be true and correct as of such date or time, and (B) to the extent that all untrue or incorrect representations and warranties set forth in this clause (a)(ii), in the aggregate, have not had and would not reasonably be expected to have a Material Adverse Effect.

(b) *Performance of the Seller's Obligations*. The Seller shall have performed in all material respects all covenants, agreements, and other obligations to be performed by it on or before the Closing Date under this Agreement.

(c) *Regulatory Consents*. All Regulatory Consents set forth on Schedule 7.1(c) shall have been obtained and are in effect as of the Closing Date.

(d) *No Material Adverse Effect*. Since the date of this Agreement, there shall not have occurred any event, condition, or circumstance that, individually or in the aggregate, has had or would reasonably be expected to have a Material Adverse Effect that has not been cured by the Seller or waived by the Purchaser in accordance with this Agreement.

(e) *Officer's Certificate*. The Seller shall have delivered to the Purchaser a certificate, dated as of the Closing Date and signed by one of the Seller's officers, stating that the conditions set forth in Sections 7.1(a), 7.1(b), 7.1(c), and 7.1(d) have been fulfilled.

(f) *MEAG Office Lease and MEAG Rights and Assets*. The Purchaser shall have entered into the assignment and assumption of the MEAG Office Lease and other documents referred to in Section 6.15 with respect to acquiring the MEAG Rights and Assets.

(g) *Transferred Employees.* (i) All of Seller's top ten (10) highest compensated employees and (ii) ninety percent (90%) of the rest of Seller's employees shall have accepted the Purchaser's offer of employment in accordance with Section 6.11(a) to become Transferred Employees effective upon the Closing.

(h) *The Seller's Closing Deliveries.* At the Closing, the Seller shall deliver, or cause to be delivered, to the Purchaser the following:

- (i) possession of the Purchased Assets;
- (ii) a bill of sale, in the form of Exhibit B attached hereto, duly executed by the Seller (the "**Bill of Sale**");
- (iii) all files and other data and documents relating to the Purchased Assets and copies of the Purchased Contracts;
- (iv) payoff letters and appropriate termination statements under the Uniform Commercial Code and other instruments as may be requested by the Purchaser to extinguish all security interests in the Purchased Assets, except Permitted Liens, to the extent directed by the Purchaser;
- (v) a copy of the Escrow Agreement, duly executed by the Seller;
- (vi) a valid IRS Form W-9, duly executed by the Seller;
- (vii) with respect to each Real Property Lease (other than the MEAG Office Lease), an assignment and assumption of lease in the form attached hereto as Exhibit D (each, an "**Assignment and Assumption of Lease**") and duly executed by the Seller; and
- (viii) the Consents set forth on Schedule 5.5.

(i) *Intellectual Property Assignment.* The Purchaser shall have received from the Seller, to the extent necessary, a patent assignment conveying any patents included in the Purchased Assets, and a trademark assignment conveying any trademarks included in the Purchased Assets, in each case, in a form reasonably acceptable to the Purchaser.

(j) *Phase I ESAs.* The Purchaser shall have completed Phase I ESAs of the GPW Maintained Huts and any Environmental Conditions identified in such Phase I ESAs shall have been resolved to the reasonable satisfaction of the Purchaser.

(k) *Assignment and Assumption of Purchased Contracts.* The Purchaser shall have received consents (obtained as described in Section 6.7(i)) to the assignment of Purchased Contracts from counterparties representing at least (i) 95% of the Seller's dollar amount in revenue and (ii) 95% of the Seller's dollar amount in expenses, in each case for the trailing twelve months prior to the Closing.

(l) *Waiver of Conditions.* The Purchaser may waive in writing any or all of the conditions to its obligations under this Agreement, provided that the waiver of any condition to Closing by the Purchaser will in no way limit the Purchaser's right to be indemnified by the Seller pursuant to ARTICLE 10, provided, however, that if the Purchaser elects to waive the condition

set forth in Section 7.1(k) above and proceeds to Closing, then Purchaser shall have no recourse against Seller after the Closing (whether in respect of indemnification or otherwise) for Losses incurred by Purchaser arising solely from the failure of Seller to obtain and deliver any such consent to the assignment of a Purchased Contract.

7.2 Of the Seller. Subject to the provisions of Section 7.2(f), the obligations of the Seller to proceed with the transactions contemplated by this Agreement are subject to the satisfaction, on or prior to the Closing Date, of the following conditions:

(a) *Representations, Warranties of the Purchaser*. Each representation and warranty made by the Purchaser shall be true and correct in all material respects when first made and on and as of the Closing Date, except (i) for a representation and warranty that expressly speaks only as of a specific date or time which need only be true and correct as of such date or time, and (ii) to the extent that all untrue or incorrect representations and warranties, in the aggregate, would not materially impair the Purchaser's ability to perform its obligations under this Agreement or to consummate the transactions contemplated by this Agreement.

(b) *Performance of the Purchaser's Obligations*. The Purchaser shall have performed in all material respects all covenants, agreements, and other obligations to be performed by it on or before the Closing Date under this Agreement including, without limitation, delivery of the full Escrow Amount to the Escrow Agent.

(c) *Regulatory Consents*. All Regulatory Consents set forth on Schedule 7.2(c) shall have been obtained and are in effect as of the Closing Date.

(d) *Officer's Certificate*. The Purchaser shall have delivered to the Seller a certificate, dated as of the Closing Date and signed by one of the Purchaser's officers, stating that the conditions set forth in Sections 7.2(a), 7.2(b), and 7.2(c) have been fulfilled.

(e) *The Purchaser's Closing Deliveries*. At the Closing the Purchaser shall deliver, or cause to be delivered, to the Seller the following:

- (i) the Net Purchase Price payable as set forth in Section 3.1;
- (ii) an Assumption Agreement, in the form of Exhibit C attached hereto (the "*Assumption Agreement*"), duly executed by the Purchaser;
- (iii) with respect to each Real Property Lease (other than the MEAG Office Lease), an Assignment and Assumption of Lease duly executed by the Purchaser; and
- (iv) a copy of the Escrow Agreement, duly executed by the Purchaser.

(f) *Waiver of Conditions*. The Seller may waive in writing any or all of the conditions to its obligations under this Agreement, provided that the waiver of any condition to Closing by the Seller will in no way limit the Seller's right to be indemnified by the Purchaser pursuant to ARTICLE 10, except as provided in Section 6.10.

7.3 Of the Parties. The respective obligations of each party to proceed with the transactions contemplated by this Agreement are subject to the satisfaction, on or prior to the Closing Date, that there shall be no effective injunction, writ, or preliminary restraining order or any order of any nature issued by

a Governmental Authority of competent jurisdiction to the effect that the transactions contemplated by this Agreement may not be consummated as provided in this Agreement, no proceeding or lawsuit shall have been commenced by any Governmental Authority for the purpose of obtaining any such injunction, writ, or preliminary restraining order and no written notice shall have been received from any Governmental Authority indicating an intent to restrain, prevent, materially delay or restructure the transactions contemplated by this Agreement.

ARTICLE 8: Closing

Assuming the conditions to Closing set forth in this Agreement are satisfied or waived by each party, the closing of the transactions contemplated hereby (the “*Closing*”) will take place via the electronic exchange of documents and signatures and the wiring of funds, or in such other manner as the Purchaser and the Seller shall agree in writing, three (3) business days following the satisfaction of all conditions set forth in ARTICLE 7 or such other date as the Seller and the Purchaser shall mutually agree (the “*Closing Date*”) and shall be effective as of 12:01 a.m., Eastern time, on the Closing Date (the “*Effective Time*”).

ARTICLE 9: Termination

9.1 Termination. The parties may terminate this Agreement prior to the Closing as provided below:

(a) The Purchaser and the Seller may terminate this Agreement by mutual written consent at any time prior to the Closing;

(b) The Purchaser may terminate this Agreement by giving written notice to the Seller at any time prior to the Closing in the event (i) (A) the Seller breaches any representation, warranty, or covenant contained in this Agreement and such breach causes any of the conditions in Section 7.1(a) or 7.1(b) not to be satisfied, (B) the Purchaser has notified the Seller of the breach (specifying in reasonable detail such breach), and (C) the breach has continued without cure or written waiver by the Purchaser before the earlier of thirty (30) days after the Purchaser’s delivery of such notice of breach and the Termination Date, (ii) any Purchased Asset is lost, damaged, or destroyed resulting in a Material Adverse Effect pursuant to Section 6.13, or (iii) the condition in Section 7.1(d) is not satisfied;

(c) The Purchaser or the Seller may terminate this Agreement by giving written notice to the other at any time prior to the Closing, if the Closing does not occur on or before the date that is nine (9) months after the date of this Agreement (the “*Termination Date*”); provided, that if the only condition to the Closing that remains unsatisfied as of the Termination Date is the receipt of any Regulatory Consents pursuant to Section 7.1(c) or Section 7.2(c), then the Termination Date shall automatically be extended by thirty (30) days.

(d) The Seller may terminate this Agreement by giving written notice to the Purchaser at any time prior to the Closing in the event (i) the Purchaser has breached any representation, warranty, or covenant contained in this Agreement and such breach causes any of the conditions in Section 7.2(a) or 7.2(b) not to be satisfied, (ii) the Seller has notified the Purchaser of the breach (specifying in reasonable detail such breach), and (iii) the breach has continued without cure or written waiver by the Seller before the earlier of thirty (30) days after the Seller’s delivery of such notice of breach and the Termination Date;

(e) By the Purchaser, on the one hand, or the Seller, on the other hand, if a Governmental Authority shall have issued an Order or taken any other action, in any case having

the effect of restraining, enjoining or otherwise prohibiting, or attempting to restrain, enjoin or otherwise prohibit, the transactions contemplated by this Agreement, and such Order or other action is final and non-appealable; or

(f) The Purchaser may terminate this Agreement pursuant to Section 11.13.

9.2 Effect of Termination. Upon termination pursuant to Section 9.1, this Agreement will become void and of no further force and effect, except that Sections 11.1, 11.8 and 11.11 will survive indefinitely, and except that, if either party commits a breach of this Agreement prior to such termination, the other party will be entitled to the remedy of specific performance in addition to any and all other available legal or equitable remedies (including damages).

ARTICLE 10: Remedies

10.1 General Indemnification Obligation.

(a) The Seller shall indemnify and hold harmless the Purchaser and its officers, directors, employees, agents, and Affiliates (collectively, the “*Purchaser Indemnified Parties*”) from and against any and all losses, liabilities, claims, damages of any nature, penalties, fines, judgments, awards, settlements, Taxes, costs, fees, expenses (including reasonable attorneys’ fees), and disbursements, and any and all consequential, special and incidental damages, loss of future revenue or profits, diminution in value and multiples of earnings, damages, and exemplary and punitive damages (to the extent such exemplary or punitive damages are awarded to a third party in connection with a Liability Claim) (collectively “*Losses*”) based upon, arising out of, or otherwise in respect of (i) any inaccuracies in or any breach of any representation or warranty of the Seller contained in this Agreement, the Seller deliverables pursuant to Section 7.1(h) hereof or in any other certificate delivered by or on behalf of the Seller to the Purchaser in connection herewith (without giving effect to any qualifications or limitations as to “materiality,” “Material Adverse Effect” or words of similar import), (ii) any breach of any covenant or agreement of the Seller contained in this Agreement, (iii) any of the Retained Assets, (iv) any of the Retained Liabilities, including the failure of the Seller to pay, perform, satisfy, or discharge when due the Retained Liabilities, and (v) the operation of the Business or the ownership or use of the Purchased Assets prior to the Closing.

(b) The Purchaser shall indemnify and hold harmless the Seller and its officers, directors, directors, employees, agents and Affiliates (as applicable) from and against any and all Losses sustained by any of such Persons based upon, arising out of, or otherwise in respect of (i) any inaccuracies in or any breach of any representation or warranty of the Purchaser contained in this Agreement, the Purchaser deliverables pursuant to Section 7.2(e) hereof or in any other certificate delivered by or on behalf of the Purchaser to the Seller in connection herewith (without giving effect to any qualifications or limitations as to “materiality,” “Material Adverse Effect” or words of similar import), (ii) any breach of any covenant or agreement of the Purchaser contained in this Agreement, (iii) any of the Assumed Liabilities, including the failure of the Purchaser to pay, perform, satisfy, or discharge when due the Assumed Liabilities, and (iv) the operation of the Business or the ownership or use of the Purchased Assets after the Closing Date, other than Losses attributable to Seller’s breach of the representations set forth in Sections 4.21(d), 4.21(f) and 4.21(g).

10.2 Notice and Opportunity to Defend.

(a) **Notice.** As soon as is reasonably practicable after the Seller, on the one hand, or the Purchaser, on the other hand, becomes aware of any claim that it has under Section 10.1 that may result in a Loss (a “**Liability Claim**”), such party (the “**Indemnified Party**”) shall give notice thereof (a “**Claims Notice**”) to the other party (the “**Indemnifying Party**”). A Claims Notice must describe the Liability Claim in reasonable detail, and indicate the amount (estimated, if necessary and to the extent feasible) of the Loss that has been or may be suffered by the Indemnified Party. No delay in or failure to give a Claims Notice by the Indemnified Party to the Indemnifying Party pursuant to this Section 10.2(a) will adversely affect any of the other rights or remedies that the Indemnified Party has under this Agreement, or alter or relieve the Indemnifying Party of its obligation to indemnify the Indemnified Party to the extent that such delay or failure has not materially prejudiced the Indemnifying Party.

(b) The Indemnifying Party has the right, exercisable by written notice to the Indemnified Party within thirty (30) days of receipt of a Claims Notice from the Indemnified Party of the commencement or assertion of any Liability Claim in respect of which indemnity may be sought hereunder, to assume and conduct the defense of such Liability Claim against any third party claimant in accordance with the limits set forth in this Agreement with counsel selected by the Indemnifying Party and reasonably acceptable to the Indemnified Party; provided, however, that (i) the defense of such Liability Claim by the Indemnifying Party does not, in the reasonable judgment of the Indemnified Party, have a material adverse effect on the Indemnified Party; (ii) the Liability Claim solely seeks (and continues to seek) monetary damages and does not involve criminal charges; (iii) the Indemnifying Party expressly agrees in writing that as between the Indemnifying Party and the Indemnified Party, the Indemnifying Party will be solely obligated to satisfy and discharge the Liability Claim in accordance with the limits set forth in this Agreement; (iv) the Liability Claim does not involve any current customers, vendors, or employees of the Business and (v) in the case of a third-party claim relating to Taxes, such third-party claim relates solely to taxable periods ending on or before the Closing Date (the conditions set forth in clauses (i) through (v) are collectively referred to as the “**Litigation Conditions**”). If the Indemnifying Party does not assume the defense of a Liability Claim in accordance with this Section 10.2(b), the Indemnified Party may continue to defend the Liability Claim. If the Indemnifying Party has assumed the defense of a Liability Claim as provided in this Section 10.2(b), the Indemnifying Party will not be liable for any legal expenses subsequently incurred by the Indemnified Party in connection with the defense thereof; provided, however, that if (A) any of the Litigation Conditions cease to be met or (B) the Indemnifying Party fails to take reasonable steps necessary to defend diligently such Liability Claim, the Indemnified Party may assume its own defense, and the Indemnifying Party shall be liable for all reasonable costs or expenses paid or incurred in connection therewith. The Indemnifying Party or the Indemnified Party, as the case may be, will have the right to participate in (but not control), at its own expense, the defense of any Liability Claim that the other is defending as provided in this Agreement. The Indemnifying Party, if it has assumed the defense of any Liability Claim as provided in this Agreement, shall not, without the prior written consent of the Indemnified Party, consent to a settlement of, or the entry of any judgment arising from, any such Liability Claim that (x) does not include as an unconditional term thereof the giving by the claimant or the plaintiff to the Indemnified Party a complete release from all liability in respect of such Liability Claim, (y) grants any injunctive or equitable relief or (z) may reasonably be expected to have a material adverse effect on the Indemnified Party. The Indemnified Party has the right to settle any Liability Claim the defense of which has not been assumed by the Indemnifying Party.

10.3 Survivability; Limitations.

(a) The representations and warranties contained in this Agreement or in any Ancillary Agreement, any deliverables pursuant to Section 7.1(h) or Section 7.2(e) hereof, as applicable, or any other certificate delivered by or on behalf of any party to the other party in connection herewith will survive for a period ending on the eighteenth-month anniversary of the Closing Date (the “**Expiration Date**”); except that: (i) the Expiration Date for any Liability Claim relating to a breach of or inaccuracy in the representations and warranties set forth in Section 4.12 (Employee Benefit Plans), Section 4.13 (Environmental) and Section 4.21 (Taxes) will be the expiration of the applicable statute of limitations, as extended, plus a period of sixty (60) days; (ii) the Expiration Date for any Liability Claim relating to a breach of or inaccuracy in the representations and warranties set forth in Section 4.9(a) (Compliance with Laws) will be the date that is three (3) years after the Closing Date (the representations and warranties described in the foregoing clauses (i) and (ii), collectively, the “**Other Representations**”); (iii) there will be no Expiration Date for any Liability Claim relating to a breach of or inaccuracy in the representations and warranties set forth in Section 4.1 (Existence; Good Standing and Capitalization), Section 4.2 (Power), Section 4.3 (Enforceability), Section 4.6 (Property) (first sentence of paragraph (a) and second sentence of paragraph (b) only), and Section 4.27 (Brokers) (the representations and warranties described in the foregoing clause (iii), collectively, the “**Special Representations**”); and (iv) any Liability Claim pending on any Expiration Date for which a Claims Notice has been given in accordance with Section 10.2(a) on or before such Expiration Date may continue to be asserted and indemnified against until finally resolved. All of the covenants and agreements contained in this Agreement will survive after the Closing Date in accordance with their terms.

(b) Notwithstanding anything to the contrary contained in this ARTICLE 10, the Seller will not have any liability pursuant to Section 10.3(a)(i) or Section 10.3(a)(ii) (other than with respect to the Special Representations, the representations and warranties set forth in Section 4.21 (Taxes) or claims based on fraud, for which the following limitations will not apply) for Losses claimed thereunder in excess of \$8,000,000 in the aggregate.

(c) Notwithstanding anything to the contrary contained in this ARTICLE 10, the Seller will not have any liability for any Losses based upon, arising out of, or otherwise in respect of any inaccuracies in or breach of any of the Special Representations or the representations and warranties set forth in Section 4.21 (Taxes) (other than with respect to claims based on fraud, for which the following limitations will not apply) in excess of the Purchase Price in the aggregate.

(d) Notwithstanding anything to the contrary contained in this ARTICLE 10, no Indemnifying Party shall be obligated to indemnify any Indemnified Party for any Losses incurred pursuant to Section 10.1(a)(i) or 10.1(b)(i) until the aggregate amount of indemnifiable Losses incurred by the Indemnified Party has exceeded \$100,000, in which case the Indemnifying Party shall be obligated to indemnify the Indemnified Party for the full amount of Losses incurred.

(e) The right to indemnification, payment of Losses of a Purchaser Indemnified Party or for other remedies based upon any representation, warranty, covenant, or obligation of the Seller contained in or made pursuant to this Agreement will not be affected by any investigation conducted, or any knowledge acquired, with respect to the accuracy or inaccuracy of or compliance with, any such representation, warranty, covenant, or obligation.

10.4 Specific Performance. Each party’s obligation under this Agreement is unique. If any party hereto should breach its covenants under this Agreement, the parties hereto each acknowledge that it would be extremely impracticable to measure the resulting damages; accordingly, the nonbreaching party

or parties, in addition to any other available rights or remedies, may sue in equity for specific performance, and each party hereto expressly waives the defense that a remedy in damages will be adequate.

10.5 Adjustments to Purchase Price. Any payments made pursuant to Section 10.1 shall be treated for all Tax purposes as an adjustment to the Net Purchase Price, except as otherwise required by applicable Law.

10.6 Release of Indemnification Escrow Amount.

(a) Upon the final resolution of any Liability Claim (which shall be by (a) written agreement of the parties hereto or (b) final, non-appealable order of a court of competent jurisdiction) pursuant to which the Seller is obligated to make any indemnity payment to the Purchaser pursuant to Section 10.1(a) (the “**Indemnity Resolution Date**”), the Seller and the Purchaser shall deliver a joint written instruction to the Escrow Agent not later than two (2) business days after the Indemnity Resolution Date instructing the Escrow Agent to release to the Purchaser from the account holding the Indemnification Escrow Amount an amount in cash equal to the amount to be paid by the Seller to the Purchaser set forth in the written agreement described in clause (a) above or the court order described in clause (b) above (the “**Seller Indemnity Payment**”); provided, that if the available Indemnification Escrow Amount is less than the amount of the Seller Indemnity Payment, then (i) the Seller and the Purchaser shall instruct the Escrow Agent to release all of the Indemnification Escrow Amount to the Purchaser and (ii) the Seller shall pay the difference between the remaining Indemnification Escrow Amount and the Seller Indemnity Payment to the Purchaser by wire transfer of immediately available funds not later than two (2) business days after the Indemnity Resolution Date.

(b) On the first anniversary of the Closing Date the Seller and the Purchaser shall deliver a joint written instruction to the Escrow Agent instructing the Escrow Agent to release to the Seller one half of the remaining Escrow Amount; provided, that if any Liability Claim, pursuant to which a Claims Notice has previously been delivered, remains unresolved on the first anniversary of the Closing Date, there shall be no release of any Escrow Amount on such date.

(c) On the eighteenth-month anniversary of the Closing Date (the “**Escrow Release Date**”), the Seller and the Purchaser shall deliver a joint written instruction to the Escrow Agent instructing the Escrow Agent to release to the Seller all of the remaining Escrow Amount; provided, that if any Liability Claim pursuant to which a Claims Notice was delivered prior to the applicable Expiration Date remains unresolved on the Escrow Release Date (an “**Unresolved Claim**”), the Seller and the Purchaser shall deliver a joint written instruction to the Escrow Agent instructing the Escrow Agent to release to the Seller an amount equal to (i) the remaining Escrow Amount minus (ii) the amount claimed by the Purchaser in such Claims Notice. Not later than two (2) business days after the final resolution of all Unresolved Claims, the Seller and the Purchaser shall deliver a joint written instruction to the Escrow Agent and the terms of Section 10.6(a) above shall apply to the release of the remaining Indemnification Escrow Amount.

10.7 Exclusive Remedy. Except for claims based on fraud and as provided in Section 9.2 and Section 10.4, the right of the parties to assert indemnification claims and receive indemnity payments under this Agreement is the sole and exclusive right and remedy exercisable by the parties with respect to any Losses arising out of any breach by any party of any representation, warranty, covenant, or agreement of such party set forth in this Agreement or otherwise relating to this Agreement and the transactions contemplated hereby. No party will have any other remedy (statutory, equitable, common law or otherwise) against any other party with respect to such matters, and all such other remedies are hereby waived. Without limiting the foregoing, each of the parties acknowledges that it will not have any remedy after the Closing

for any breach of any representation, warranty, covenant, or agreement set forth in this Agreement, except as expressly provided in this ARTICLE 10.

ARTICLE 11: Miscellaneous

11.1 Press Release and Announcements. No party hereto shall issue any press release or other public announcement relating to the subject matter of this Agreement or the transactions contemplated hereunder without the prior approval of the other party hereto, which approval shall not be unreasonably withheld, conditioned or delayed; provided that the Purchaser may issue or cause the publication of a “tombstone” or similar advertisement without the consent of the Seller. Nothing in this Section 11.1 will restrict the Purchaser or any of its Affiliates’ ability to disclose information to the Purchaser’s, or any of its Affiliates’, lenders, direct or indirect investors, or prospective lenders or investors.

11.2 No Assignment. The rights and obligations of the parties hereunder may not be assigned without the prior written consent of the other party hereto. Notwithstanding the previous sentence, the Purchaser may, without the consent of any Member or the Seller, assign its rights under this Agreement to any lender of the Purchaser, to any Affiliate of the Purchaser or to any purchaser of all or substantially all of the assets or business of the Purchaser. Notwithstanding anything to the contrary contained herein, in the event the Seller is dissolved or winds up following the Closing, the Members shall designate one of the Members to take all actions that otherwise would have been taken by the Seller hereunder.

11.3 Headings. The headings contained in this Agreement are included for purposes of convenience only, and will not affect the meaning or interpretation of this Agreement.

11.4 Integration, Modification and Waiver. This Agreement, together with the Exhibits, Schedules and certificates or other instruments delivered hereunder, constitutes the entire agreement between the parties hereto with respect to the subject matter hereof and supersedes all prior understandings of the parties. No supplement, modification or amendment of this Agreement will be binding unless executed in writing by each of the parties hereto. No waiver of any of the provisions of this Agreement will be deemed to be or will constitute a continuing waiver. No waiver will be binding unless executed in writing by the party making the waiver.

11.5 Construction. The parties hereto have participated jointly in the negotiation and drafting of this Agreement. In the event an ambiguity or question of intent or interpretation arises, this Agreement will be construed as if drafted jointly by the parties hereto and no presumption or burden of proof will arise favoring or disfavoring any party hereto by virtue of the authorship of any of the provisions of this Agreement. Any reference to any federal, state, or local statute or law will be deemed also to refer to all rules and regulations promulgated thereunder, unless the context requires otherwise. The word “including” means including without limitation. Any reference to the singular in this Agreement shall also include the plural and vice versa.

11.6 Severability. If any provision of this Agreement or the application of any provision hereof to any party or circumstance is, to any extent, adjudged invalid or unenforceable, the application of the remainder of such provision to such party or circumstance, the application of such provision to other parties or circumstances, and the application of the remainder of this Agreement will not be affected thereby.

11.7 Notices. All notices and other communications required or permitted hereunder must be in writing and will be deemed to have been duly given when delivered in person or when dispatched by electronic mail (with evidence of such dispatch) or facsimile, or one (1) business day after having been dispatched by a nationally recognized overnight courier service to the appropriate party at the address specified below:

If to the Seller:

Georgia Public Web, Inc.
1470 Riveredge Parkway
Atlanta, GA 30328
Attention: Eric Snell
Email: esnell@gapublicweb.net

c/o Georgia Public Web, Inc.
120 N. Louise Avenue
Calhoun, GA 30701
Attention: Brad Carrick
Email: bcarrick@calnet-ga.net

with a copy to:

Friend, Hudak & Harris, LLP
Three Ravinia Drive, Suite 1700
Atlanta, GA 30346
Attention: Scott K. Harris; Charles Hudak
Email: sharris@fh2.com; chudak@fh2.com

If to the Purchaser:

c/o Macquarie Capital
125 West 55th Street
New York NY 10019
Attention: John Spirtos; Andrew Ancone
Email: john.spiritos@macquarie.com; andrew.ancone@macquarie.com

with a copy to:

c/o Macquarie Capital
125 West 55th Street
New York NY 10019
Attention: Melissa Toomey; Andrew Underwood
Email: melissa.toomey@macquarie.com;
andrew.underwood@macquarie.com

and

Goodwin Procter LLP
620 8th Avenue
New York, NY
Attention: Ilan S. Nissan; Michael R. Patrone
Email: inissan@goodwinlaw.com; mpatrone@goodwinlaw.com

Any party hereto may change its address, email, or facsimile number for the purposes of this Section 11.7 by giving notice as provided herein.

11.8 Governing Law. This Agreement shall be governed by and construed and enforced in accordance with the laws of the State of Delaware, without regard to principles of conflicts of law.

11.9 Counterparts. This Agreement may be executed in one or more counterparts (including facsimile or other electronically transmitted counterparts), each of which will be deemed an original, but all of which together will constitute one and the same instrument.

11.10 Jurisdiction. Except for the matters to be decided by the Arbitration Firm pursuant to Section 3.2, the parties hereto hereby submit to the exclusive jurisdiction of the state courts in and for the state of Delaware or, if jurisdiction is unavailable in such courts, the courts of the United States located in the District of Delaware, in each case, in respect of the interpretation and enforcement of the provisions of this Agreement and any dispute or controversy related to the transactions contemplated hereby and hereby waive, and agree not to assert, any defense in any action, suit, or proceeding for the interpretation or enforcement of this Agreement or any dispute or controversy related to the transactions contemplated hereby, that they are not subject thereto or that such action, suit, or proceeding may not be brought or is not maintainable in such courts or that this Agreement may not be enforced in or by such courts or that their property is exempt or immune from execution, that the suit, action, or proceeding is brought in an inconvenient forum, or that the venue of the suit, action, or proceeding is improper. Service of process with respect thereto may be made upon any party hereto by mailing a copy thereof by registered or certified mail, postage prepaid, to such party at its address as provided in Section 11.7.

11.11 Expenses. Except as provided above or as otherwise expressly provided herein, each party shall pay its own fees, costs, and expenses incurred in connection with this Agreement and the transactions contemplated by this Agreement, including the fees, costs, and expenses of its financial advisors, accountants, and counsel.

11.12 Waiver of Jury Trial. Each party hereto acknowledges and agrees that any controversy that may arise under this Agreement, including any exhibits, schedules, attachments and appendices attached to this Agreement, is likely to involve complicated and difficult issues and, therefore, each such party irrevocably and unconditionally waives any right it may have to a trial by jury in respect of any legal action arising out of or relating to this Agreement, including any exhibits, schedules, attachments and appendices attached to this Agreement, or the transactions contemplated hereby. Each party hereto certifies and acknowledges that (a) no representative of the other party has represented, expressly or otherwise, that such other party would not seek to enforce the foregoing waiver in the event of a legal action, (b) such party has considered the implications of this waiver, (c) such party makes this waiver voluntarily, and (d) such party has been induced to enter into this Agreement by, among other things, the mutual waivers and certifications in this Section 11.12.

11.13 Risk of Loss. The risk of any loss or damage to the Purchased Assets resulting from fire, theft, or any other casualty (except reasonable wear and tear) will be borne by the Seller at all times prior to the Closing. In the event that any such loss or damage is sufficiently substantial so as to create a Material Adverse Effect, the Seller will immediately notify the Purchaser and, at any time within thirty (30) days after its receipt of such notice, the Purchaser may by written notice to the Seller elect to either (a) waive such defect and proceed toward consummation of the transactions in accordance with the terms of this Agreement or (b) terminate this Agreement. If the Purchaser does not elect to terminate this Agreement notwithstanding such loss or damage, (i) all insurance proceeds payable as a result of the occurrence of the event resulting in such loss or damage will be delivered by the Seller to the Purchaser, or the rights thereto will be assigned by the Seller to the Purchaser, if not yet paid over to the Seller, and the Seller will pay to the Purchaser the amount of the deductibles with respect to the relevant insurance policies and (ii) the Purchase Price will be reduced by the amount of the replacement cost of the Purchased Assets that were

lost, damaged, or destroyed less the amount of any proceeds of insurance payable as a result of the occurrence.

[Signature Pages Follow]

In witness whereof, the parties have executed this Agreement as of the day and year first above written.

The Purchaser:
[Macquarie Newco, LLC]

By: _____
Name:
Title:

By: _____
Name:
Title:

The Seller:
Georgia Public Web, Inc.

By: _____
Name: Eric Snell
Title: CEO & President

**WRITTEN CONSENT
OF THE MEMBERS OF
GEORGIA PUBLIC WEB, INC.**

ALL MEMBERS AND ALL PERCENTAGES

1.	City of Adel	3.184%
2.	City of Albany	11.574%
3.	City of Barnesville	1.158%
4.	City of Blakely	1.544%
5.	City of Cairo	2.315%
6.	City of Calhoun	4.245%
7.	City of Camilla	1.544%
8.	City of Cartersville	5.400%
9.	City of Commerce	1.544%
10.	City of Covington	3.473%
11.	Crisp County Power Commission	2.701%
12.	City of Douglas	3.082%
13.	City of Elberton	2.315%
14.	City of Ellaville	1.158%
15.	City of Fairburn	2.547%
16.	City of Fitzgerald	2.701%
17.	City of Forsyth	1.544%
18.	City of Fort Valley	2.315%
19.	City of Griffin	5.017%
20.	City of LaGrange	0.637%
21.	City of Marietta	11.963%
22.	City of Monticello	2.547%
23.	City of Moultrie	3.087%
24.	City of Newnan	5.094%
25.	City of Norcross	1.544%
26.	City of Palmetto	1.158%
27.	City of Quitman	1.544%
28.	City of Sandersville	1.544%
29.	City of Sylvania	1.930%
30.	City of Thomaston	1.930%
31.	City of Thomasville	5.731%
32.	City of Washington	<u>1.930%</u>
		100.00%

**RESOLUTION
REGARDING DISTRIBUTION OF MONIES
FROM SALE OF ASSETS OF GEORGIA PUBLIC WEB, INC.**

WHEREAS, The Mayor and the City Council and The Board of Water, Sewerage and Light Commissioners of the City of Newnan have approved the execution of the Fourth Amendment to The Telecommunications Project Contract dated May 1, 1996 between the City of Newnan, The Board of Water, Sewerage and Light Commissioners of the City of Newnan and the Municipal Electric Authority of Georgia; and

WHEREAS, the Mayor and the City Council and The Board of Water, Sewerage and Light Commissioners of the City of Newnan have approved the Written Consent of The Members of Georgia Public Web, Inc. to enter into the transaction set out in the Asset Purchase Agreement between the Corporation and the party name therein; and

WHEREAS, The Board of Water, Sewerage and Light Commissioners of the City of Newnan advanced all monies for participation in The Telecommunications Project and should receive all monies accruing to the participants from the sale of the assets of Georgia Public Web, Inc.

NOW THEREFORE, BE IT RESOLVED and it is hereby resolved by the Mayor and City Council of the City of Newnan that all monies distributed in connection with the sale of the assets of Georgia Public Web, Inc. due to the City of Newnan and The Board of Water, Sewerage and Light Commissioners of the City of Newnan be transmitted to the order of or to the appropriately designated account of The Board of Water, Sewerage and Light Commissioners of the City of Newnan.

SO RESOLVED in open session, regularly assembled this ____ day of _____, 2022.

ATTEST:

Megan Shea, City Clerk

L. Keith Brady, Mayor

Rhodes H. Shell, Mayor Pro-Tem

REVIEWED AS TO FORM:

C. Bradford Sears, Jr., City Attorney

George M. Alexander, Councilmember

Cleatus Phillips, City Manager

Cynthia E. Jenkins, Councilmember

Raymond F. DuBose, Councilmember

Dustin Koritko, Councilmember

Paul Guillaume, Councilmember



December 9, 2021,

Newnan City Council,

Let me first thank the council for your continued support of making Newnan a great city for both pedestrians and cyclists. Facilities like C Jay Smith Park and the LINC are extremely valuable to the health and wellness of our community and Bike Coweta thanks you for your leadership.

Bike Coweta is making plans for the 2nd Annual Rock & Road Festival for our community to be held April 22-24, 2022.. The festival offers cycling and community events both in downtown as well as throughout the county. The weekend's events promise to bring 800-1000 visitors to our community.

Bike Coweta seeks approval of the Newnan City Council for closing down South Court Square on April 23, 2022 from noon to 8pm in order to entertain both visiting cyclists as well as Cowetans to downtown for music and food. This past year's event was a huge success and local businesses benefited from the festival given the increased pedestrian traffic that the festival created.

We look forward to your approval of our request to close South Court Square and welcome any suggestions on how to make the event a better experience for everyone.

Regards,

A handwritten signature in black ink, appearing to read "Chris Doane", written in a cursive style.

Chris Doane,

Bike Coweta Board Chair

Motion to Enter into Executive Session

I move that we now enter into closed session as allowed by O.C.G.A. §50-14-4 and pursuant to advice by the City Attorney, for the purpose of discussing

And that we, in open session, adopt a resolution authorizing and directing the Mayor or presiding officer to execute an affidavit in compliance with O.C.G.A. §50-14-4, and that this body ratify the actions of the Council taken in closed session and confirm that the subject matters of the closed session were within exceptions permitted by the open meetings law.

Motion to Adopt Resolution after Adjourning Back into Regular Session

I move that we adopt the resolution authorizing the Mayor to execute the affidavit stating that the subject matter of the closed portion of the council meeting was within the exceptions provided by O.C.G.A. §50-14-4(b).